

bdiAccess

JTAG interface library

MIPS32



Installation Manual

Manual Version 1.01 for BDI2000

abatron

© 1992-2011 ABATRON AG

1 Introduction	3
1.1 BDI2000.....	3
2 Installation	4
2.1 Connecting the BDI2000 to Target	4
2.1.1 Changing Target Processor Type	6
2.2 Connecting the BDI2000 to Power Supply	7
2.2.1 External Power Supply.....	7
2.2.2 Power Supply from Target System	8
2.3 Status LED «MODE».....	9
2.4 Connecting the BDI2000 to the Host.....	10
2.4.1 Serial line communication	10
2.4.2 Ethernet communication	11
2.5 Installation of the Configuration Software.....	12
2.6 BDI2000 Setup/Update.....	13
2.6.1 Linux/Unix Hosts	13
2.6.2 Windows Hosts	14
2.6.3 Recover procedure.....	15
3 Specifications	16
4 Environmental notice.....	17
5 Declaration of Conformity (CE).....	17
6 Abatron Warranty and Support Terms	18
6.1 Hardware	18
6.2 Software	18
6.3 Warranty and Disclaimer	18
6.4 Limitation of Liability	18
 Appendices	
A Troubleshooting	19
B Maintenance.....	20
C Trademarks	22

1 Introduction

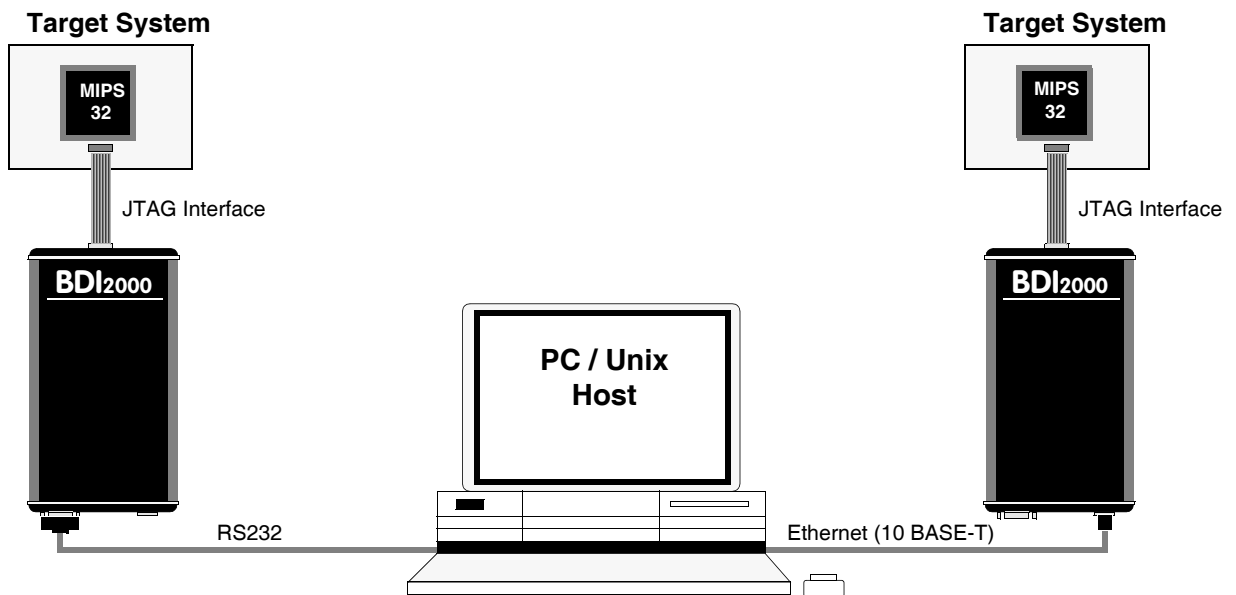

The bdiAccess library can be used to access the BDI2000 functions. With this library, a program running on a Windows/Linux/Unix host can take advantage of the JTAG interface of an MIPS32 based target processor and execute the following tasks:

- Read/Write target registers
- Read/Write target memory
- Reset/Startup target
- Flash programming
- Start/Stop program execution

This Installation Manual shows how to connect the BDI2000 to a MIPS32 based target and how to install the bdiAccess software. The interface to the library is defined in a different document that is target independent.

1.1 BDI2000

The BDI2000 is a processor system in a small box. It implements the interface between the JTAG pins of the target CPU and a 10Base-T Ethernet / RS232 connector. The firmware and the programmable logic of the BDI2000 can be updated by the user with a simple Windows based configuration program. The BDI2000 supports 1.8 – 5.0 Volts target systems (3.0 – 5.0 Volts target systems with Rev. A/B).

2 Installation

2.1 Connecting the BDI2000 to Target

The cables to the target system are designed for the IDT RC32300 Development Boards (optional available: Part# 90070) and for EJTAG 2.5 compatible boards (enclosed). In case where the target system has the same connector layout, the cable (14 pin or 24 pin) can be directly connected.



In order to ensure reliable operation of the BDI (EMC, runtimes, etc.) the target cable length must not exceed 25 cm (10").

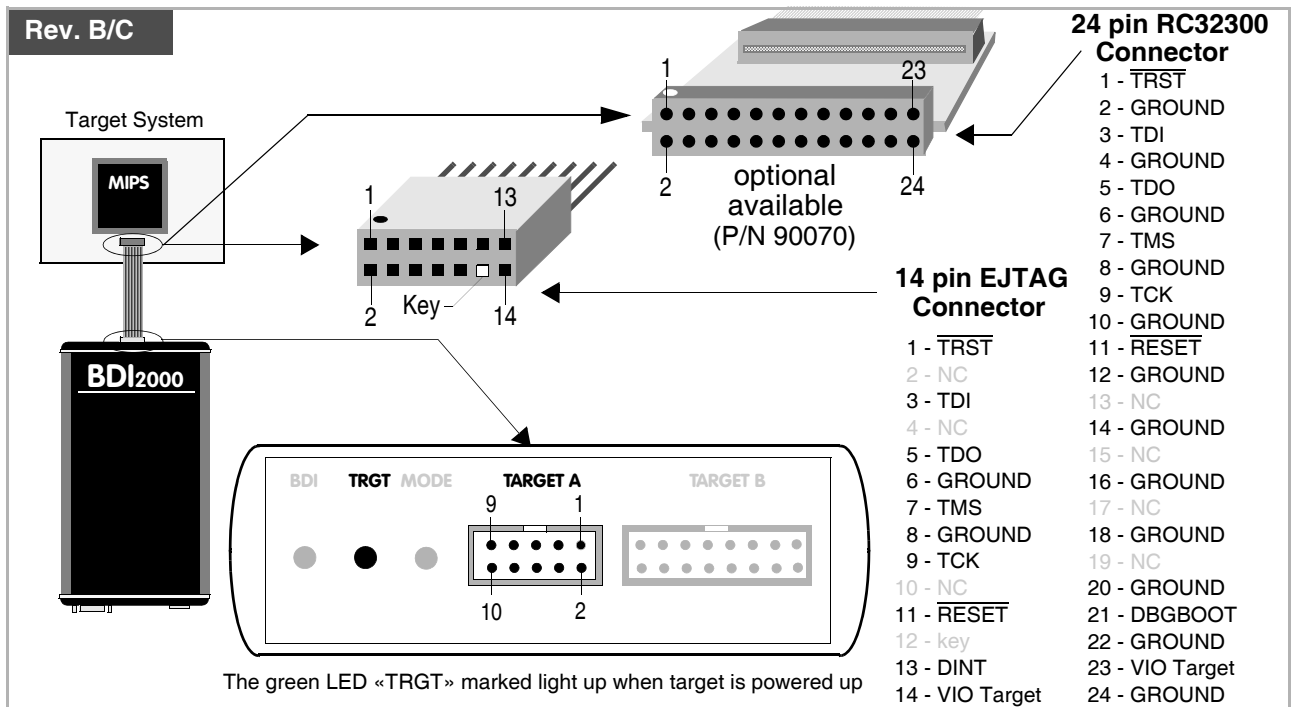
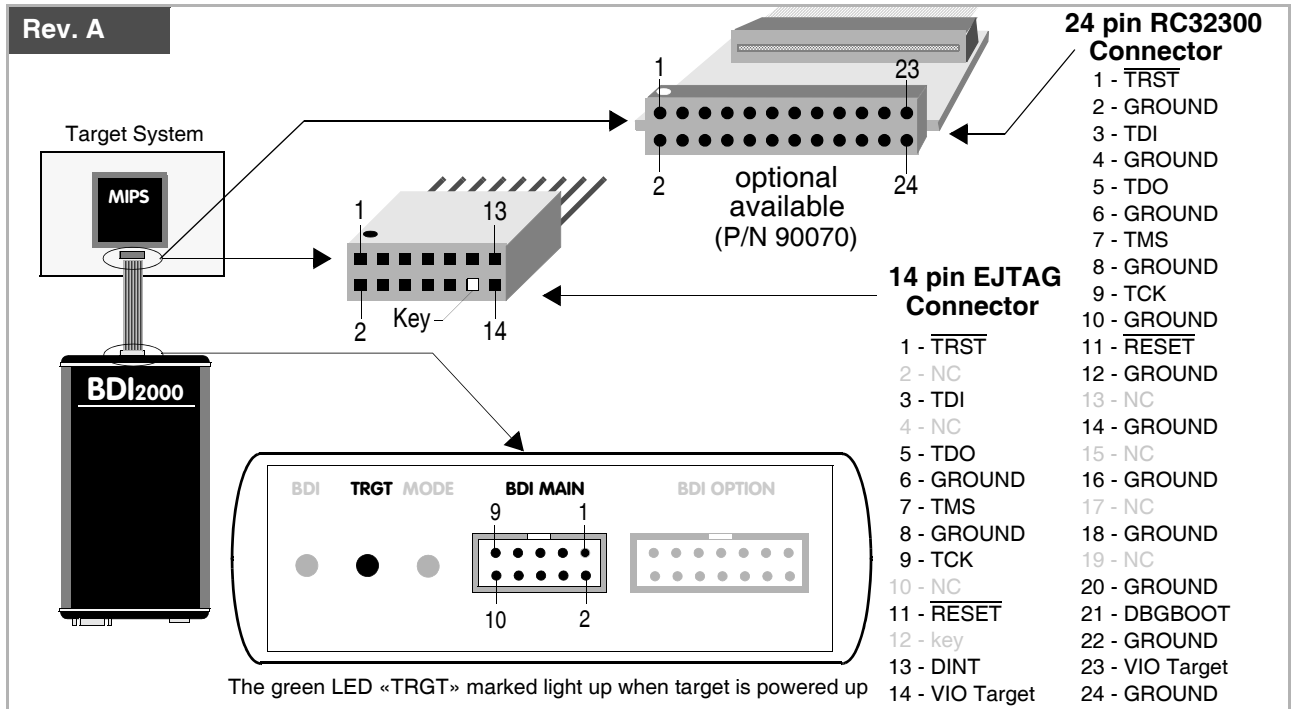

For BDI MAIN / TARGET A connector signals see table on next page.

BDI MAIN / TARGET A Connector Signals

Pin	Name	Description
1	DINT	EJTAG Debug Interrupt EJTAG 2.5: This output of the BDI2000 connects to the target DINT line. RC32300: This output of the BDI2000 connects to the target DebugBoot line.
2	$\overline{\text{TRST}}$	EJTAG Test Reset This output of the BDI2000 resets the JTAG TAP controller on the target.
3+5	GND	System Ground
4	TCK	EJTAG Test Clock This output of the BDI2000 connects to the target TCK line.
6	TMS	EJTAG Test Mode Select This output of the BDI2000 connects to the target TMS line.
7	$\overline{\text{RESET}}$	This open collector output of the BDI2000 is used to reset the target system.
8	TDI	EJTAG Test Data In This output of the BDI2000 connects to the target TDI line.
9	VIO Target	1.8 – 5.0V: This is the target reference voltage. It indicates that the target has power and it is also used to create the logic-level reference for the input comparators. It also controls the output logic levels to the target. It is normally fed from Vdd I/O on the target board. 3.0 – 5.0V with Rev. A/B : This input to the BDI2000 is used to detect if the target is powered up. If there is a current limiting resistor between this pin and the target Vdd, it should be 100 Ohm or less.
10	TDO	EJTAG Test Data Out This input to the BDI2000 connects to the target TDO line.

2.1.1 Changing Target Processor Type

Before you can use the BDI2000 with an other target processor type (e.g. ARM <--> MIPS), a new setup has to be done (see chapter 2.5). During this process the target cable must be disconnected from the target system. The BDI2000 needs to be supplied with 5 Volts via the BDI OPTION connector (Rev. A) or via the POWER connector (Rev. B/C). For more information see chapter 2.2.1 «External Power Supply»).



To avoid data line conflicts, the BDI2000 must be disconnected from the target system while programming the logic for an other target CPU.

2.2 Connecting the BDI2000 to Power Supply

2.2.1 External Power Supply

The BDI2000 needs to be supplied with 5 Volts (max. 1A) via the BDI OPTION connector (Rev. A) or via POWER connector (Rev. B/C). The available power supply from Abatron (option) or the enclosed power cable can be directly connected. In order to ensure reliable operation of the BDI2000, keep the power supply cable as short as possible.



For error-free operation, the power supply to the BDI2000 must be between 4.75V and 5.25V DC. **The maximal tolerable supply voltage is 5.25 VDC. Any higher voltage or a wrong polarity might destroy the electronics.**

Rev. A

The green LED «BDI» marked light up when 5V power is connected to the BDI2000

BDI OPTION Connector

- 1 - NOT USED
- 2 - GROUND
- 3 - NOT USED
- 4 - GROUND
- 5 - NOT USED
- 6 - GROUND
- 7 - NOT USED
- 8 - GROUND
- 9 - NOT USED
- 10 - GROUND
- 11 - NOT USED
- 12 - Vcc (+5V)
- 13 - Vcc Target (+5V)
- 14 - Vcc (+5V)

Rev. B/C

The green LED «BDI» marked light up when 5V power is connected to the BDI2000

POWER Connector

- 1 - Vcc (+5V)
- 2 - VccTGT
- 3 - GROUND
- 4 - NOT USED

Please switch on the system in the following sequence:

- 1 --> external power supply
- 2 --> target system

2.2.2 Power Supply from Target System

The BDI2000 needs to be supplied with 5 Volts (max. 1A) via BDI MAIN target connector (Rev. A) or via TARGET A connector (Rev. B/C). This mode can only be used when the target system runs with 5V and the pin «Vcc Target» is able to deliver a current up to 1A@5V. For pin description and layout see chapter 2.1 «Connecting the BDI2000 to Target». Insert the enclosed Jumper as shown in figure below. **Please ensure that the jumper is inserted correctly.**



For error-free operation, the power supply to the BDI2000 must be between 4.75V and 5.25V DC. **The maximal tolerable supply voltage is 5.25 VDC. Any higher voltage or a wrong polarity might destroy the electronics.**

Rev. A

BDI OPTION Connector

- 1 - NOT USED
- 2 - GROUND
- 3 - NOT USED
- 4 - GROUND
- 5 - NOT USED
- 6 - GROUND
- 7 - NOT USED
- 8 - GROUND
- 9 - NOT USED
- 10 - GROUND
- 11 - NOT USED
- 12 - Vcc (+5V)
- 13 - Vcc Target (+5V)
- 14 - Vcc BDI2000 (+5V)

The green LEDs «BDI» and «TRGT» marked light up when target is powered up and the jumper is inserted correctly

Rev. B/C

POWER Connector

- 1 - Vcc BDI2000 (+5V)
- 2 - Vcc Target (+5V)
- 3 - GROUND
- 4 - NOT USED

The green LEDs «BDI» and «TRGT» marked light up when target is powered up and the jumper is inserted correctly

2.3 Status LED «MODE»

The built in LED indicates the following BDI states:

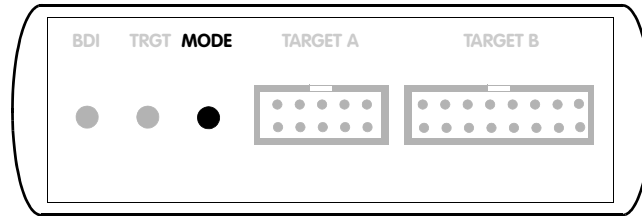

MODE LED	BDI STATES
OFF	The BDI is ready for use, the firmware is already loaded.
ON	The power supply for the BDI2000 is < 4.75VDC.
BLINK	The BDI «loader mode» is active (an invalid firmware is loaded or loading firmware is active).

2.4 Connecting the BDI2000 to the Host

2.4.1 Serial line communication

The host is connected to the BDI through the serial interface (COM1...COM4). The communication cable between BDI and Host is a serial cable (RXD / TXD are crossed). There is the same connector pinout for the BDI and for the Host side (Refer to Figure below).

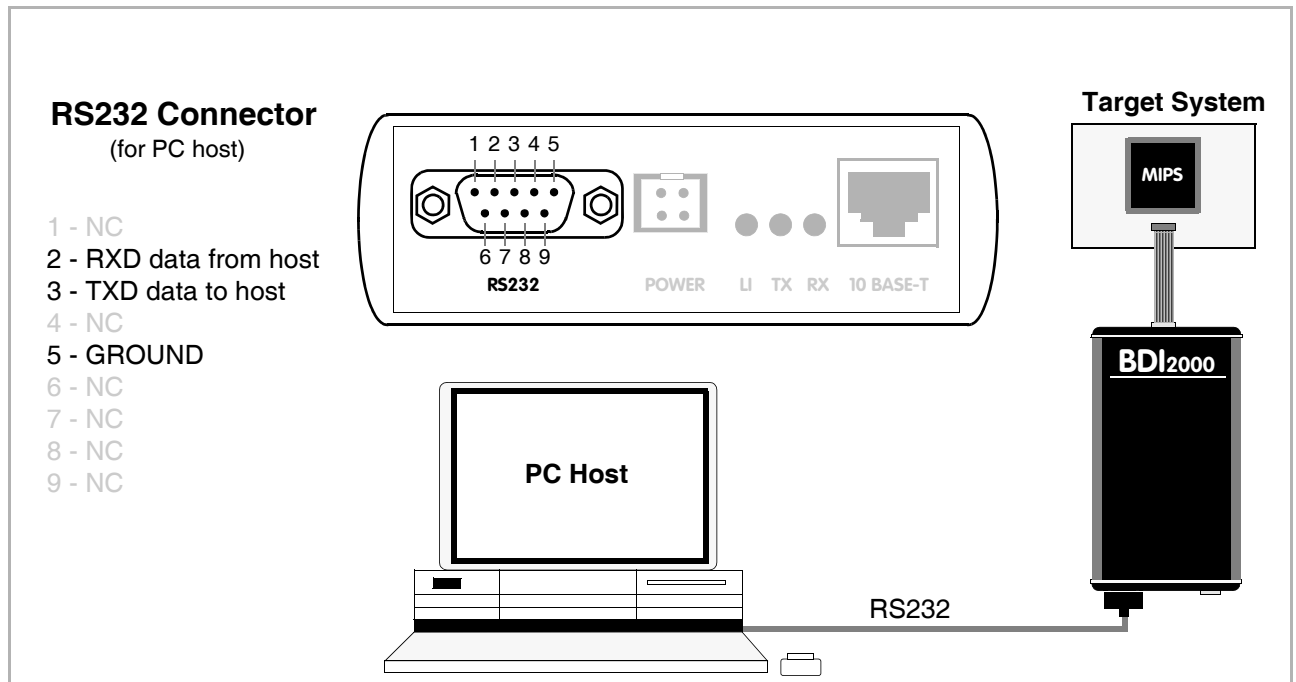

2.4.2 Ethernet communication

The BDI2000 has a built-in 10 BASE-T Ethernet interface (see figure below). Connect an UTP (Unshielded Twisted Pair) cable to the BDI2000. For thin Ethernet coaxial networks you can connect a commercially available media converter (BNC-->10 BASE-T) between your network and the BDI2000. Contact your network administrator if you have questions about the network.

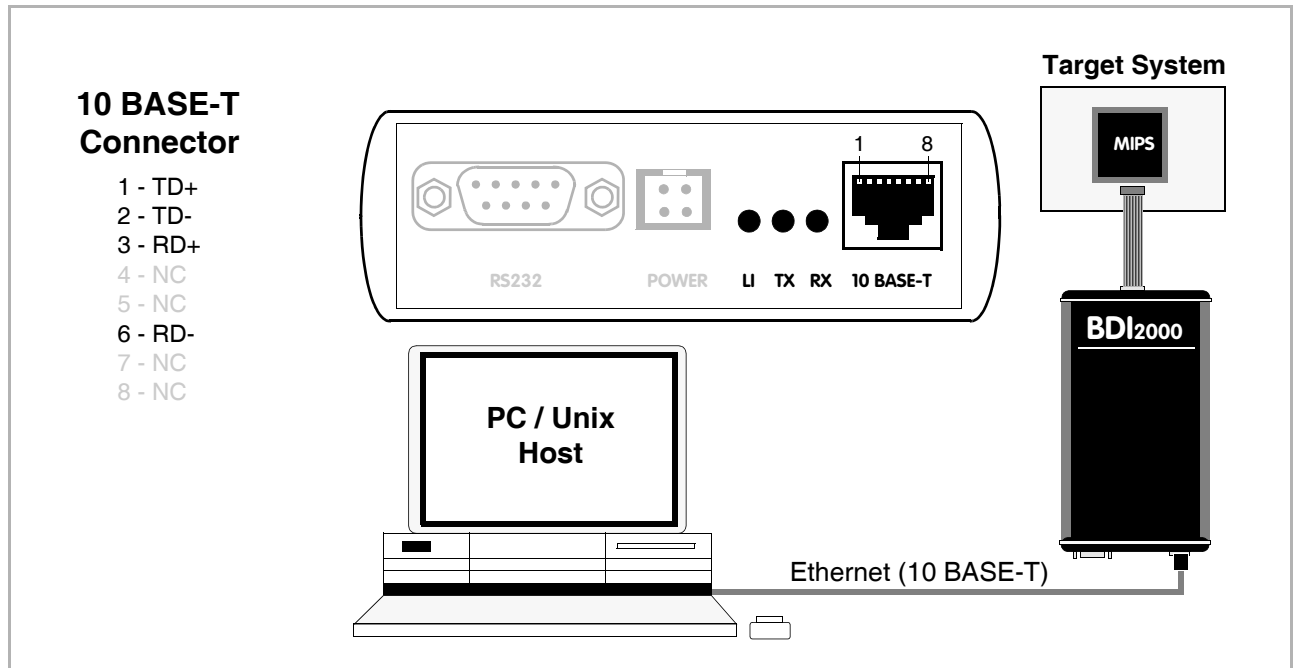

The following explains the meanings of the built-in LED lights:

LED	Name	Description
LI	Link	When this LED light is ON, data link is successful between the UTP port of the BDI2000 and the hub to which it is connected.
TX	Transmit	When this LED light BLINKS, data is being transmitted through the UTP port of the BDI2000
RX	Receive	When this LED light BLINKS, data is being received through the UTP port of the BDI2000

2.5 Installation of the Configuration Software

On the enclosed CD you will find the bdiAccess library, the BDI configuration software and the firmware required for the BDI. Copy the appropriate files to a directory on your hard disk.

Windows and Linux/Unix hosts:

manual.pdf	This installation manual in pdf format
bdiacc.pdf	The bdiAccess interface specification in pdf format
b20r4kfw.xxx	Firmware for BDI2000 for MIPS32 targets
r4kjed20.xxx	JEDEC file for the BDI2000 (Rev. A/B) logic device programming
r4kjed21.xxx	JEDEC file for the BDI2000 (Rev. C) logic device programming

Only for Windows hosts:

b20r4kfw.exe	Setup program (WIN32 application)
bdiifc32.dll	The bdiAccess library (WIN32-DLL)
bdiifc32.lib	The import library for the bdiAccess DLL (WIN32)
bdiifc.h	The C header file showing the interface to the bdiAccess DLL

Only for Linux/Unix hosts:

bdiacc_inx.zip	Archive with the bdiAccess sources for Linux/Unix hosts
bdisetup.zip	Archive with the BDI setup utility sources for Linux/Unix hosts

2.6 BDI2000 Setup/Update

First make sure that the BDI is properly connected (see Chapter 2.1 to 2.4). The BDI must be connected via RS232 to the Windows host.



To avoid conflicts between data lines, the BDI2000 must be disconnected from the target system while programming the logic for an other target CPU (see Chapter 2.1.1).

2.6.1 Linux/Unix Hosts

In order to update the firmware / logic of the BDI and to set the network parameters, a setup tool is included for Linux/Unix hosts. In the ZIP Archive `bdisetup.zip` are all sources to build this utility. This command line utility can be used to update the firmware and logic of the BDI2000. It is also used to transfer the network configuration. There are 4 tasks the utility can process:

- Reading the current loaded firmware / logic version
- Erasing the firmware and logic
- Updating the firmware and logic
- Storing the network configuration parameters into the BDI flash

Every of this task is started by executing the setup utility with different parameters. The first parameter always selects the task to execute:

```
bdisetup { -v | -e | -u | -c } [additional parameters]
-v      Read version
-e      Erase firmware and logic
-u      Update firmware and/or logic
-c      Store network configuration
```

There are two common additional parameters which define the serial port and the serial baudrate:

```
-pP     Port to use, replace P with the port to use e.g. /dev/ttyS0
-bB     Baudrate to use, replace B with 9, 19, 38, 57 or 115
```

Additional parameters for update (-u):

```
-aA     Application type, replace A with ACC
-tT     Target type, replace T with MIPS
-dD     Replace D with the directory with the firmware/logic files
```

Additional parameters for network configuration (-c):

```
-iI     Replace I with the BDI IP address (format: xxx.xxx.xxx.xxx)
-mM     Replace M with the subnet mask.
        A subnet mask of 255.255.255.255 disables the gateway function
-gG     Replace G with the default gateway IP address
```

All parameters have default values. See function `main()`. You may adjust this default values for your convenience. See also `bdisetup.c` and document `BDIACC.PDF` for additional information

To build the setup utility use: `gcc bdisetup.c bdidll.c -o bdisetup`

2.6.2 Windows Hosts

After starting the Windows setup tool, the following dialog box will be displayed.

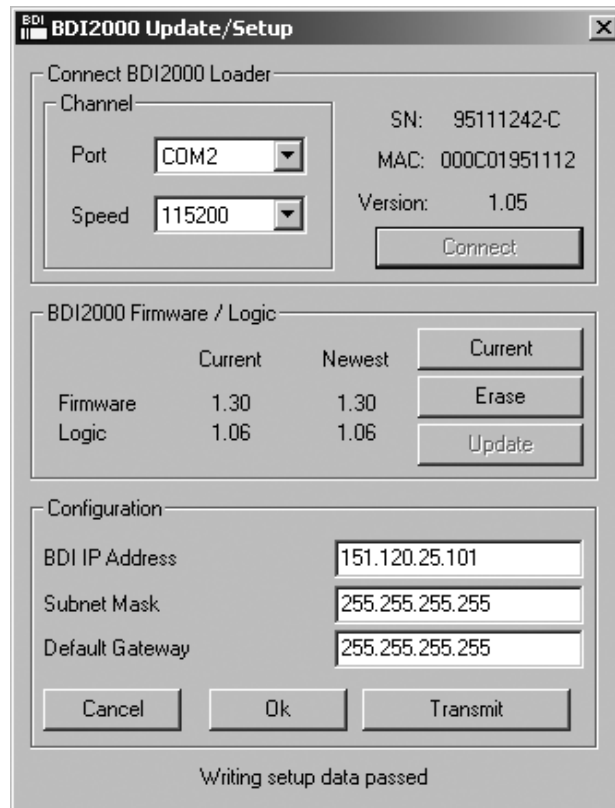

dialog box «BDI2000 Update/Setup»

The following options allow you to update the BDI2000 firmware and store the network parameters:

- Port** Select the communication port where the BDI2000 is connected during this setup session.
- Speed** Select the baudrate used to communicate with the BDI2000 loader during this setup session.
- Connect** Click on this button to establish a connection with the BDI2000 loader. Once connected, the BDI2000 remains in loader mode until it is restarted or this dialog box is closed.
- Current** Press this button to read back the current loaded BDI2000 firmware version. The current firmware version will be displayed.
- Erase** Press this button to erase the current loaded firmware.
- Update** This button is only active if there is a newer firmware version present in the execution directory of the setup software. Press this button to write the new firmware into the BDI2000 flash memory.

BDI IP Address	Enter the IP address for the BDI2000. Use the following format: xxx.xxx.xxx.xxx e.g.151.120.25.101 Ask your network administrator for assigning an IP address to this BDI2000. Every BDI2000 in your network needs a different IP address.
Subnet Mask	Enter the subnet mask of the network where the BDI is connected to. Use the following format: xxx.xxx.xxx.xx.e.g.255.255.255.0 A subnet mask of 255.255.255.255 disables the gateway feature. Ask your network administrator for the correct subnet mask.
Default Gateway	Enter the IP address of the default gateway. Ask your network administrator for the correct gateway IP address. If the gateway feature is disabled, you may enter 255.255.255.255 or any other value.
Transmit	Click on this button to store the configuration in the BDI2000 flash memory.

2.6.3 Recover procedure

In rare instances you may not be able to load the firmware in spite of a correctly connected BDI (error of the previous firmware in the flash memory). **Before carrying out the following procedure, check the possibilities in Appendix «Troubleshooting».** In case you do not have any success with the tips there, do the following:

- Switch OFF the power supply for the BDI and open the unit as described in Appendix «Maintenance»
- Place the jumper in the «**INIT MODE**» position
- Connect the power cable or target cable if the BDI is powered from target system
- Switch ON the power supply for the BDI again and wait until the LED «MODE» blinks fast
- Turn the power supply OFF again
- Return the jumper to the «**DEFAULT**» position
- Reassemble the unit as described in Appendix «Maintenance»

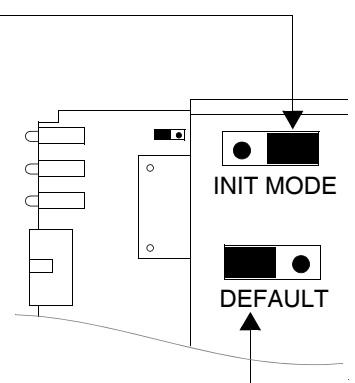

3 Specifications

Operating Voltage Limiting	5 VDC \pm 0.25 V
Power Supply Current	typ. 500 mA max. 1000 mA
RS232 Interface: Baud Rates	9'600, 19'200, 38'400, 57'600, 115'200
Data Bits	8
Parity Bits	none
Stop Bits	1
Network Interface	10 BASE-T
Serial Transfer Rate between BDI and Target	up to 16 Mbit/s
Supported target voltage	1.8 – 5.0 V (3.0 – 5.0 V with Rev. A/B)
Operating Temperature	+ 5 °C ... +60 °C
Storage Temperature	-20 °C ... +65 °C
Relative Humidity (noncondensing)	<90 %rF
Size	190 x 110 x 35 mm
Weight (without cables)	420 g
Host Cable length (RS232)	2.5 m

Specifications subject to change without notice

4 Environmental notice

Disposal of the equipment must be carried out at a designated disposal site.

5 Declaration of Conformity (CE)

DECLARATION OF CONFORMITY

This declaration is valid for following product:

Type of device: BDM/JTAG Interface
Product name: BDI2000

The signing authorities state, that the above mentioned equipment meets the requirements for emission and immunity according to

EMC Directive 89/336/EEC

The evaluation procedure of conformity was assured according to the following standards:

EN 50081-2
EN 50082-2

This declaration of conformity is based on the test report no. QNL-E853-05-8-a of QUINEL, Zug, accredited according to EN 45001.

Manufacturer:

ABATRON AG
Stöckenstrasse 4
CH-6221 Rickenbach

Authority:

Max Vock
Marketing Director

Ruedi Dummermuth
Technical Director

Rickenbach, May 30, 1998

6 Abatron Warranty and Support Terms

6.1 Hardware

ABATRON Switzerland warrants that the Hardware shall be free from defects in material and workmanship for a period of 3 years following the date of purchase when used under normal conditions. Failure in handling which leads to defects or any self-made repair attempts are not covered under this warranty. In the event of notification within the warranty period of defects in material or workmanship, ABATRON will repair or replace the defective hardware. The customer must contact the distributor or Abatron for a RMA number prior to returning.

6.2 Software

License

Against payment of a license fee the client receives a usage license for this software product, which is not exclusive and cannot be transferred.

Copies

The client is entitled to make copies according to the number of licenses purchased. Copies exceeding this number are allowed for storage purposes as a replacement for defective storage mediums.

Update and Support

The agreement includes free software maintenance (update and support) for one year from date of purchase. After this period the client may purchase software maintenance for an additional year.

6.3 Warranty and Disclaimer

ABATRON AND ITS SUPPLIERS HEREBY DISCLAIMS AND EXCLUDES, TO THE EXTENT PERMITTED BY APPLICABLE LAW, ALL WARRANTIES, EXPRESS OR IMPLIED, INCLUDING WITHOUT LIMITATION, ANY WARRANTIES OF MERCHANTABILITY, FITNESS FOR A PARTICULAR PURPOSE, TITLE AND NON-INFRINGEMENT.

6.4 Limitation of Liability

IN NO EVENT SHALL ABATRON OR ITS SUPPLIERS BE LIABLE TO YOU FOR ANY DAMAGES, INCLUDING, WITHOUT LIMITATION, ANY SPECIAL, INDIRECT, INCIDENTAL OR CONSEQUENTIAL DAMAGES, ARISING OUT OF OR IN CONNECTION WITH THE USE OR PERFORMANCE OF THE HARDWARE AND/OR SOFTWARE, INCLUDING WITHOUT LIMITATION, LOSS OF PROFITS, BUSINESS, DATA, GOODWILL, OR ANTICIPATED SAVINGS, EVEN IF ADVISED OF THE POSSIBILITY OF THOSE DAMAGES.

The hardware and software product with all its parts, copyrights and any other rights remain in possession of ABATRON. Any dispute, which may arise in connection with the present agreement shall be submitted to Swiss Law in the Court of Zug (Switzerland) to which both parties hereby assign competence.

Appendices

A Troubleshooting

Problem

The firmware can not be loaded.

Possible reasons

- The BDI is not correctly connected with the target system (see chapter 2).
- The power supply of the target system is switched off or not in operating range (4.75 VDC ... 5.25 VDC) --> MODE LED is OFF or RED
- The built in fuse is damaged --> MODE LED is OFF
- The BDI is not correctly connected with the Host (see chapter 2).
- A wrong communication port (Com 1...Com 4) is selected.

Problem

No working with the target system (loading firmware is ok).

Possible reasons

- Wrong pin assignment (BDM/JTAG connector) of the target system (see chapter 2).
- Target system initialization is not correctly --> enter an appropriate target initialization list.
- An incorrect IP address was entered (BDI2000 configuration)
- BDM/JTAG signals from the target system are not correctly (short-circuit, break, ...).
- The target system is damaged.

Problem

Network processes do not function (loading the firmware was successful)

Possible reasons

- The BDI2000 is not connected or not correctly connected to the network (LAN cable or media converter)
- An incorrect IP address was entered (BDI2000 configuration)

B Maintenance

The BDI needs no special maintenance. Clean the housing with a mild detergent only. Solvents such as gasoline may damage it.

If the BDI is connected correctly and it is still not responding, then the built in fuse might be damaged (in cases where the device was used with wrong supply voltage or wrong polarity). To exchange the fuse or to perform special initialization, please proceed according to the following steps:



Observe precautions for handling (Electrostatic sensitive device)
Unplug the cables before opening the cover.
Use exact fuse replacement (Microfuse MSF 1.6 AF).

1

1.1 Unplug the cables

2

2.1 Remove the two plastic caps that cover the screws on target front side (e.g. with a small knife)

2.2 Remove the two screws that hold the front panel

3

3.1 While holding the casing, remove the front panel and the red elastic sealing

4

4.1 While holding the casing, slide carefully the print in position as shown in figure below

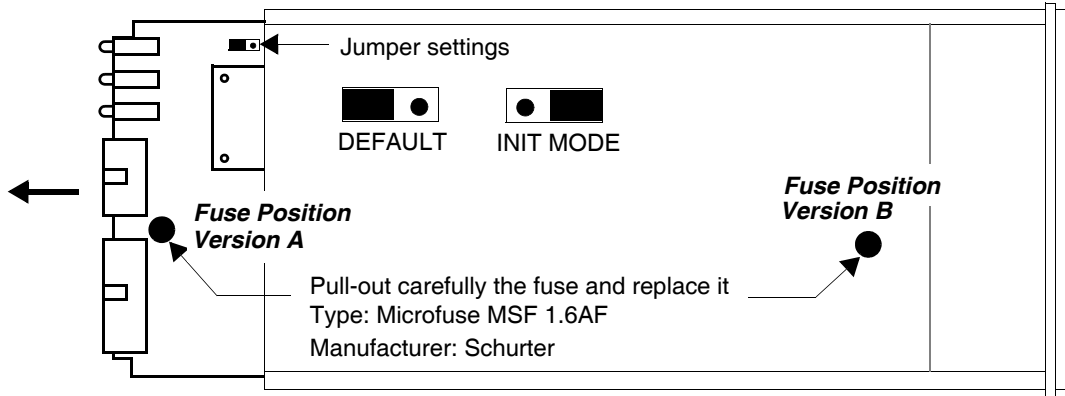

5

Reinstallation

5.1 Slide back carefully the print. Check that the LEDs align with the holes in the back panel.

5.2 Push carefully the front panel and the red elastic sealing on the casing. Check that the LEDs align with the holes in the front panel and that the position of the sealing is as shown in the figure below.

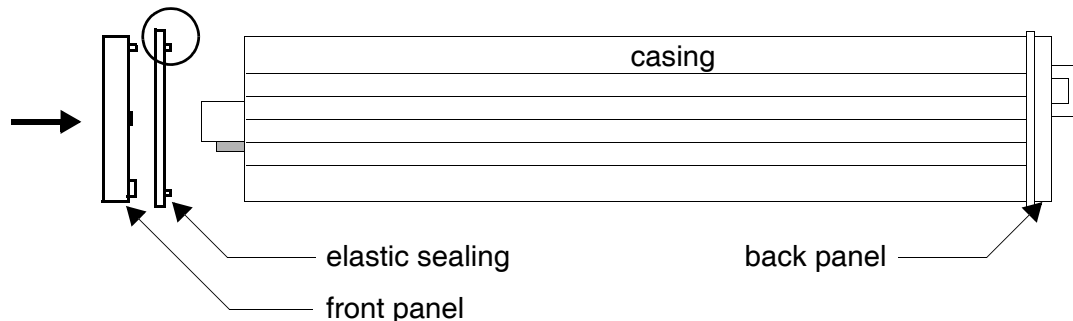

5.3 Mount the screws (do not overtighten it)

5.4 Mount the two plastic caps that cover the screws

5.5 Plug the cables



**Observe precautions for handling (Electrostatic sensitive device)
Unplug the cables before opening the cover.
Use exact fuse replacement (Microfuse MSF 1.6 AF).**

C Trademarks

All trademarks are property of their respective holders.