

*bedi*CW

BDM interface for CodeWarrior™ Debugger

ColdFire



User Manual

Manual Version 1.04 for BDI2000



© 1992-2004 ABATRON AG

1 Introduction	3
1.1 BDI2000.....	3
2 Installation	4
2.1 Connecting the BDI2000 to Target.....	4
2.1.1 Changing Target Processor Type	6
2.2 Connecting the BDI2000 to Power Supply.....	7
2.2.1 External Power Supply	7
2.2.2 Power Supply from Target System	8
2.3 Status LED «MODE»	9
2.4 Connecting the BDI2000 to the Host.....	10
2.4.1 Serial line communication	10
2.4.2 Ethernet communication	11
2.5 Installation of the Configuration Software	12
2.6 Configuration	13
2.6.1 BDI2000 Setup/Update	14
3 Init List.....	16
4 BDI working modes.....	17
4.1 Startup Mode	18
4.1.1 Startup mode RESET	18
4.1.2 Startup Mode STOP	18
4.1.3 Startup mode RUN.....	19
4.2 Breakpoint Mode	19
4.2.1 Breakpoint Mode FREEZED	19
4.2.2 Breakpoint Mode LOOP	19
4.3 Workspace.....	21
5 Specifications	22
6 Warranty	23
 Appendices	
A Troubleshooting	24
B Maintenance	25
C Trademarks	27

1 Introduction

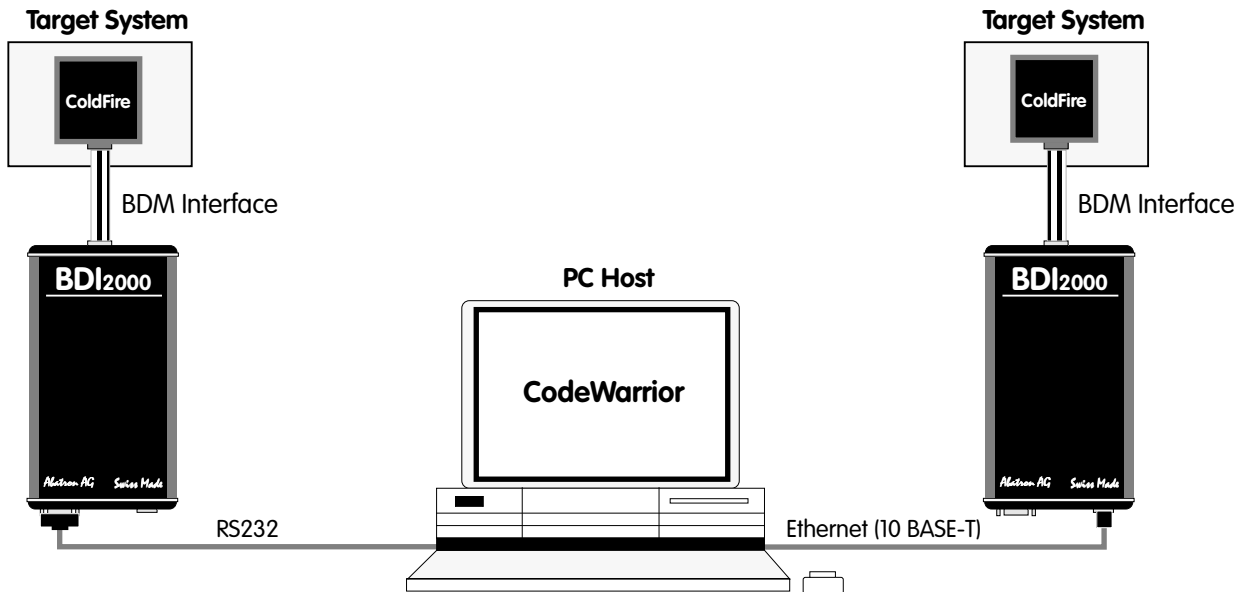

The BDI2000 adds Background Debug Mode features to the CodeWarrior debugger environment from Metrowerks. With the BDI2000, you control and monitor the microcontroller solely through the stable on-chip debugging services. You won't waste time and target resources with a software ROM monitor, and you eliminate the cabling problems typical of ICE's. This combination runs even when the target system crashes and allows developers to continue investigating the cause of the crash. A RS232 interface with a maximum of 115 kBaud and a 10Base-T Ethernet interface is available for the host interface.

The configuration software is used to update the firmware and to configure the BDI2000 so it works with the CodeWarrior debugger.

1.1 BDI2000

The BDI2000 is a processor system in a small box. It implements the interface between the BDM pins of the target CPU and a 10Base-T Ethernet / RS232 connector. BDI2000 is powered by a MC68360, 512Kbyte RAM and a flash memory of 1024Kbyte. As a result of consistent implementation of latest technology, the BDI2000 is optimally prepared for further enhancements. The firmware and the programmable logic of the BDI2000 can be updated by the user with a simple Windows based configuration program. The BDI2000 supports 1.8 – 5.0 Volts target systems (3.0 – 5.0 Volts target systems with Rev. B).

2 Installation

2.1 Connecting the BDI2000 to Target

The enclosed cable to the target system is designed for the Motorola recommended 26-pin Berg connector. In case where the target system has an appropriate connector, the cable can be directly connected. The pin assignment is in accordance with the Motorola specification.



In order to ensure reliable operation of the BDI (EMC, runtimes, etc.) the target cable length must not exceed 20 cm (8").

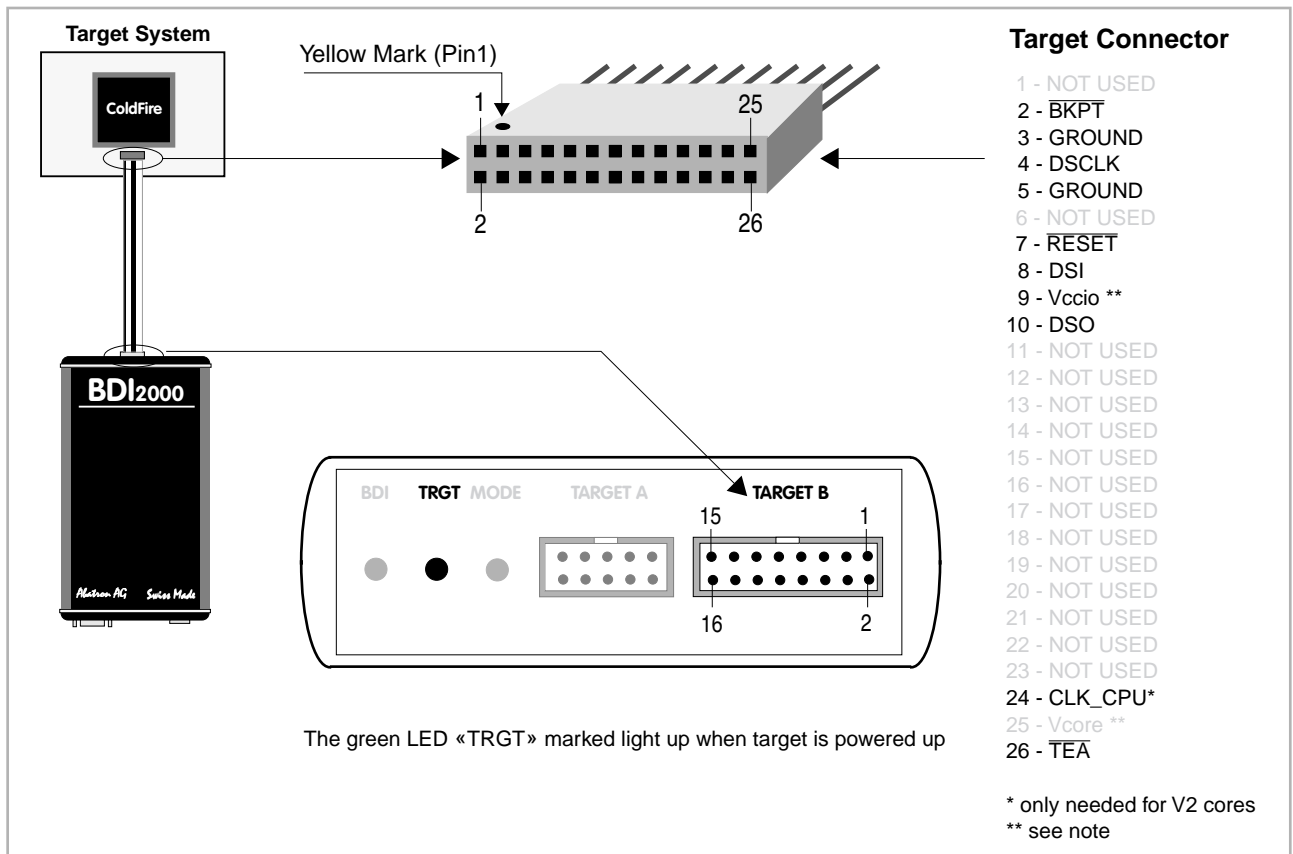

The target CPU clock is only needed for older V2 cores (MCF5204, MCF5206(e) and MCF5272) because DSCLK and DSI have to change synchronous with the CPU clock. For all other cores, BDM communication can be asynchronous to the CPU clock and therefore this signal is not needed.



Important note for older target cables:

The target cables delivered before October 2004 expect the target BDM reference voltage (Vccio) at pin 25 of the BDM connector. For target boards where Vccio is only routed to pin 9, remove the contact/wire from housing pin 25 and insert it into pin 9.

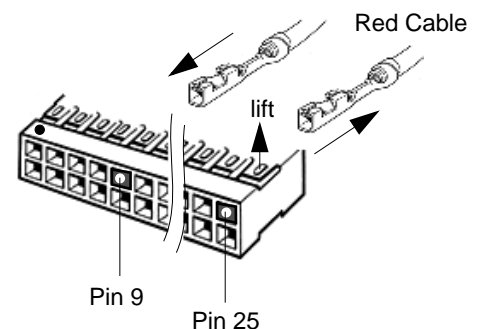

BDI TARGET B Connector Signals:

Pin	Name	Description
1	DSO	DATA SERIAL OUT For background debug mode, serial data output from the MCU.
2	<reseved>	
3	DSI	DATA SERIAL IN For background debug mode, serial data input signal to the MCU.
4	<reseved>	
5	<reseved>	
6	Vcc Target	1.8 – 5.0V: This is the target reference voltage. It indicates that the target has power and it is also used to create the logic-level reference for the input comparators. It also controls the output logic levels to the target. It is normally fed from Vdd I/O on the target board. 3.0 – 5.0V with Rev. B : This input to the BDI2000 is used to detect if the target is powered up. If there is a current limiting resistor between this pin and the target Vdd, it should be 100 Ohm or less.
7	DSCLK	DEVELOPMENT SERIAL CLOCK For background debug mode, serial shift clock to the MCU.
8	$\overline{\text{BKPT}}$	BREAKPOINT BKPT is an active-low signal that signals a hardware breakpoint for the ColdFire core. It is used to force the ColdFire core to enter debug mode.
9	$\overline{\text{TEA}}$ (optional)	TRANSFER ERROR ACKNOWLEDGE (currently not implemented) Active-low open-drain signal, used to abort a bus cycle. This signal may be helpful for ColdFire devices which has no built-in bus monitor (e.g. MCF5307). The BDI is able to terminate an invalid memory access. Otherwise BDM communication may hang until a reset is applied.
10	<reseved>	
11	<reseved>	
12	GROUND	System Ground
13	$\overline{\text{RESET}}$	RESET Active-low open-drain signal, used to force a system reset.
14	CLK_CPU	PROCESSOR CLOCK For some cores, this clock signal is used to synchronize the BDM signals DSCLK and DSI.
15	<reseved>	
16	GROUND	System Ground

Pin 14 is only use for some older V2 cores (MCF5204, MCF5206(e) and MCF5272). For all other cores this signal is not used.

2.1.1 Changing Target Processor Type

Before you can use the BDI2000 with an other target processor type (e.g. ColdFire <--> PPC), a new setup has to be done (see Appendix A). During this process the target cable must be disconnected from the target system. The BDI2000 needs to be supplied with 5 Volts via the BDI OPTION connector (Rev. A) or via the POWER connector (Rev. B). For more information see chapter 2.2.1 «External Power Supply».



To avoid data line conflicts, the BDI2000 must be disconnected from the target system while programming the logic for an other target CPU.

2.2 Connecting the BDI2000 to Power Supply

2.2.1 External Power Supply

The BDI2000 needs to be supplied with 5 Volts (max. 1A) via the POWER connector. The available power supply from Abatron (option) or the enclosed power cable can be directly connected. In order to ensure reliable operation of the BDI2000, keep the power supply cable as short as possible.



For error-free operation, the power supply to the BDI2000 must be between 4.75V and 5.25V DC. **The maximal tolerable supply voltage is 5.25 VDC. Any higher voltage or a wrong polarity might destroy the electronics.**

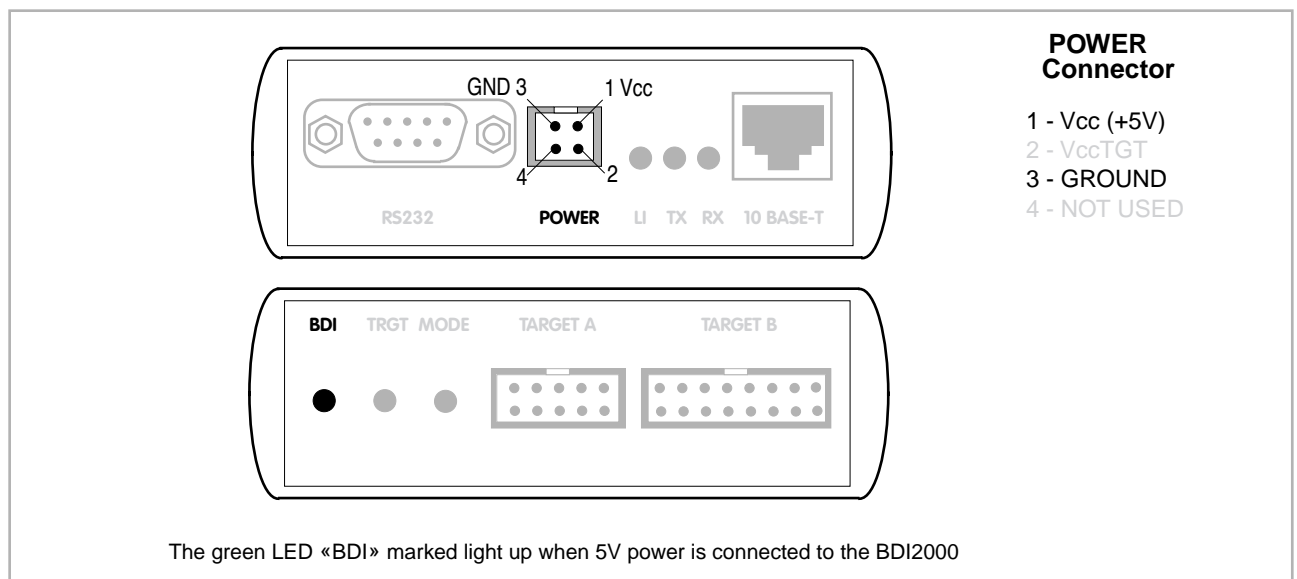

Please switch on the system in the following sequence:

- 1 --> external power supply
- 2 --> target system

2.2.2 Power Supply from Target System

The BDI2000 needs to be supplied with 5 Volts (max. 1A) via TARGET B connector. This mode can only be used when the target system runs with 5V and the pin «Vcc Target» is able to deliver a current up to 1A@5V. For pin description and layout see chapter 2.1 «Connecting the BDI2000 to Target». Insert the enclosed Jumper as shown in figure below. **Please ensure that the jumper is inserted correctly.**



For error-free operation, the power supply to the BDI2000 must be between 4.75V and 5.25V DC. **The maximal tolerable supply voltage is 5.25 VDC. Any higher voltage or a wrong polarity might destroy the electronics.**

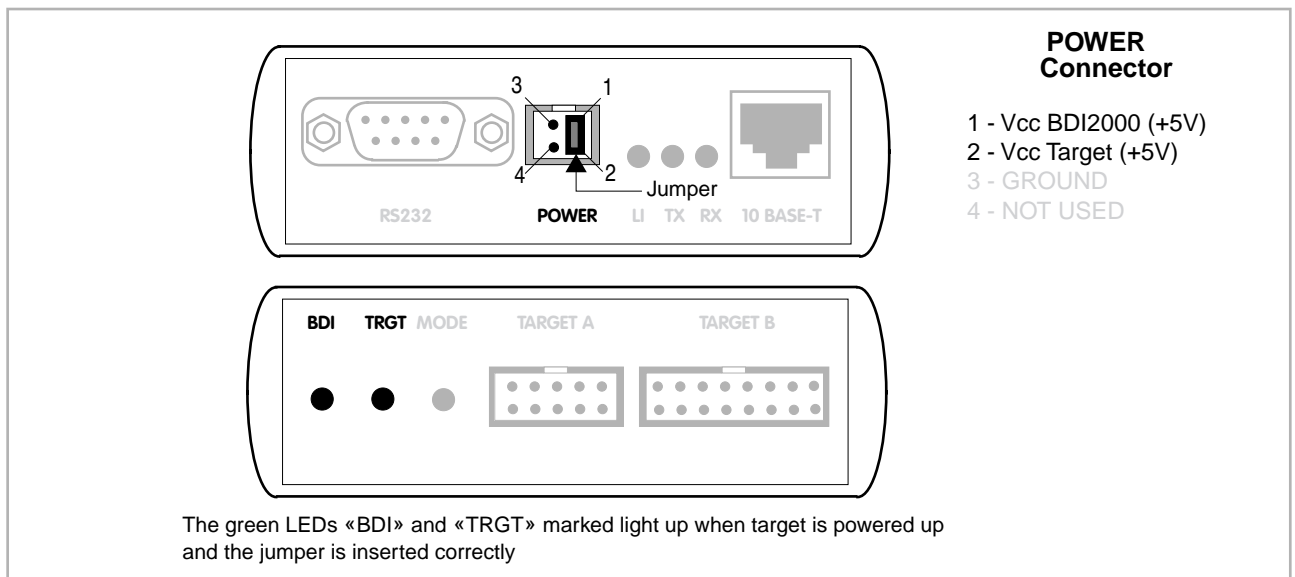

2.3 Status LED «MODE»

The built in LED indicates the following BDI states:

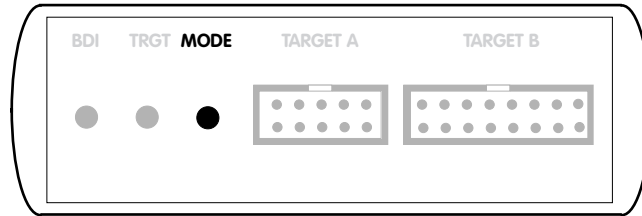

MODE LED	BDI STATES
OFF	The BDI is ready for use, the firmware is already loaded.
ON	The power supply for the BDI2000 is < 4.75VDC.
BLINK	The BDI «loader mode» is active (an invalid firmware is loaded or loading firmware is active).

2.4 Connecting the BDI2000 to the Host

2.4.1 Serial line communication

The host is connected to the BDI through the serial interface (COM1...COM4). The communication cable between BDI and Host is a serial cable (RXD / TXD are crossed). There is the same connector pinout for the BDI and for the Host side (Refer to Figure below).

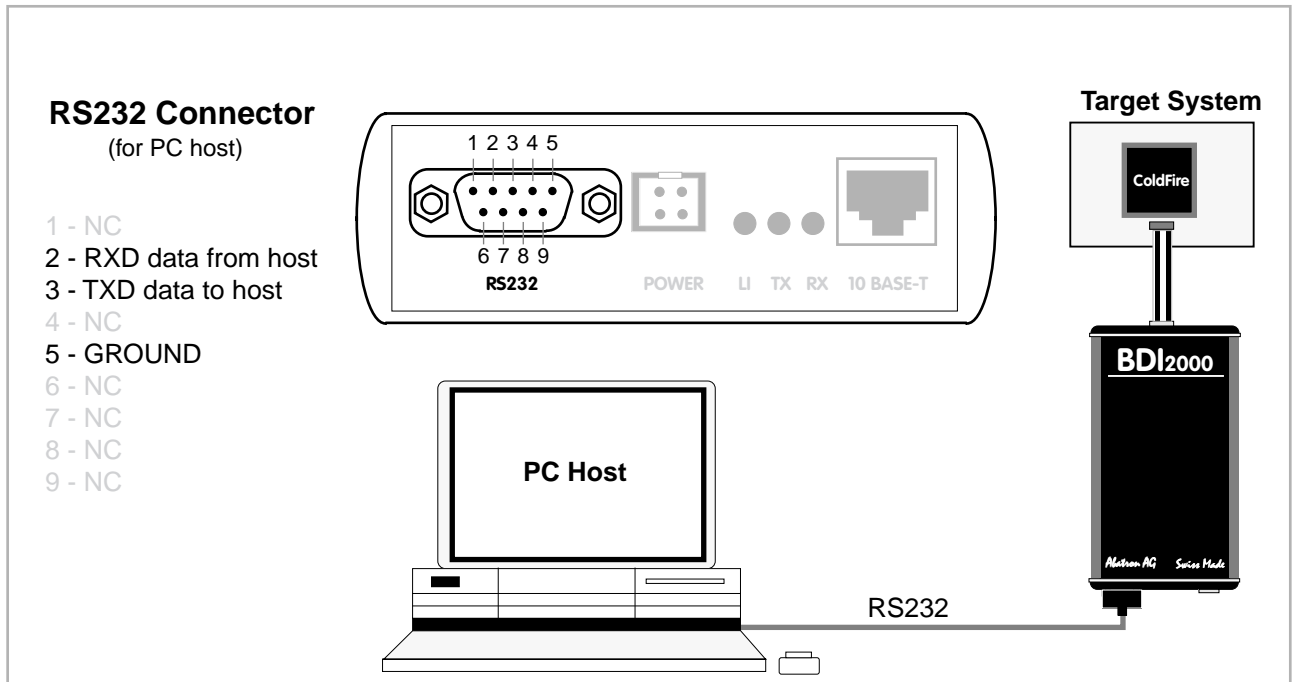

2.4.2 Ethernet communication

The BDI2000 has a built-in 10 BASE-T Ethernet interface (see figure below). Connect an UTP (Unshielded Twisted Pair) cable to the BD2000. For thin Ethernet coaxial networks you can connect a commercially available media converter (BNC-->10 BASE-T) between your network and the BDI2000. Contact your network administrator if you have questions about the network.

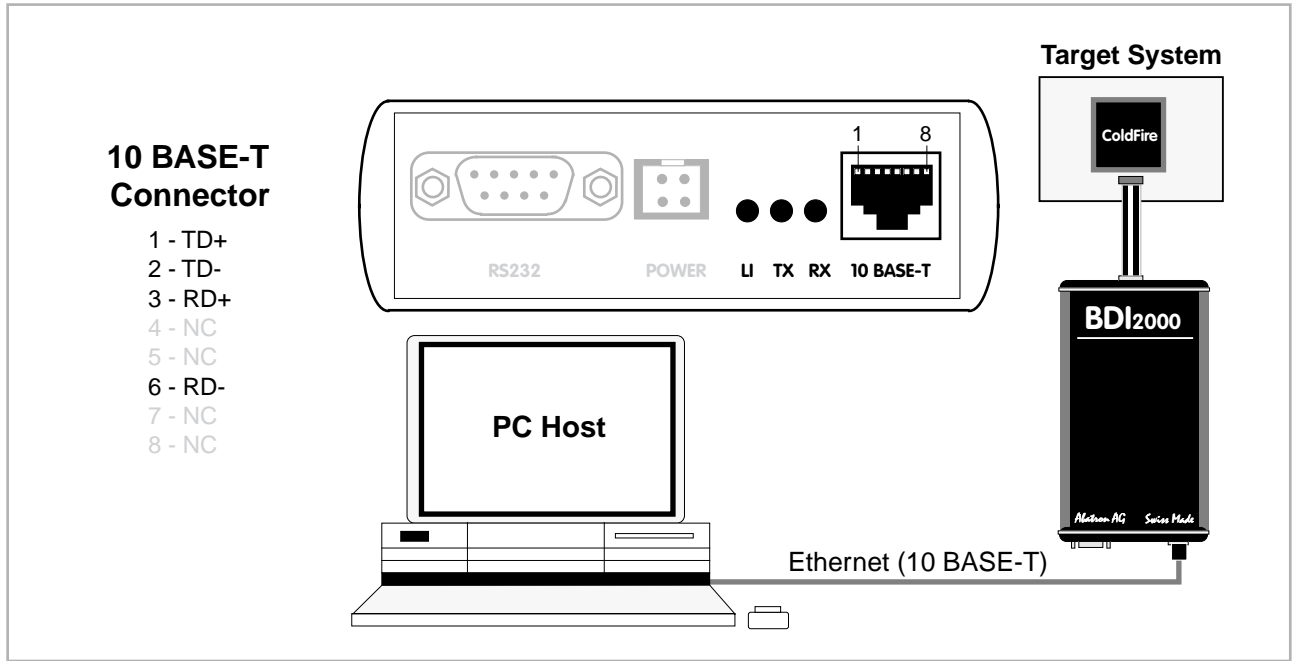

The following explains the meanings of the built-in LED lights:

LED	Name	Description
LI	Link	When this LED light is ON, data link is successful between the UTP port of the BDI2000 and the hub to which it is connected.
TX	Transmit	When this LED light BLINKS, data is being transmitted through the UTP port of the BDI2000
RX	Receive	When this LED light BLINKS, data is being received through the UTP port of the BDI2000

2.5 Installation of the Configuration Software

On the enclosed diskette you will find the BDI configuration software and the firmware required for the BDI. Copy all these files to a directory on your hard disk.

The following files are on the diskette:

b20mcf.exe	Configuration program
b20mcf.hlp	Helpfile for the configuration program
b20mcf.cnt	Help contents file
b20mcfw.xxx	Firmware for BDI2000 for ColdFire targets
cf2jed20.xxx	JEDEC file for the BDI2000 (Rev. B) logic device (for old V2 cores)
cf2jed21.xxx	JEDEC file for the BDI2000 (Rev. C) logic device (for old V2 cores)
cf3jed20.xxx	JEDEC file for the BDI2000 (Rev. B) logic device
cf3jed21.xxx	JEDEC file for the BDI2000 (Rev. C) logic device
bdiifc32.dll	BDI Interface DLL
*.bdi	Configuration Examples

Example of an installation process:

- Copy the entire contents of the enclosed diskette into a directory on the hard disk.
- You may create a new shortcut to the b20mcf.exe configuration program.

2.6 Configuration

Before you can use the BDI together with the debugger, the BDI must be configured. Use the *SETUP* menu and follow the steps listed below:

- Load or update the firmware / logic, store IP address --> *Firmware*
- Set the communication parameters between Host and BDI --> *Communication*
- Setup an initialization list for the target processor --> *Initlist*
- Select the working mode --> *Mode*
- Transmit the configuration to the BDI --> *Mode Transmit*

For information about the dialogs and menus use the help system (F1).

2.6.1 BDI2000 Setup/Update

First make sure that the BDI is properly connected (see Chapter 2.1 to 2.4). The BDI must be connected via RS232 to the Windows host.



To avoid data line conflicts, the BDI2000 must be disconnected from the target system while programming the logic for an other target CPU (see Chapter 2.1.1).

The following dialogbox is used to check or update the BDI firmware and logic and to set the network parameters.

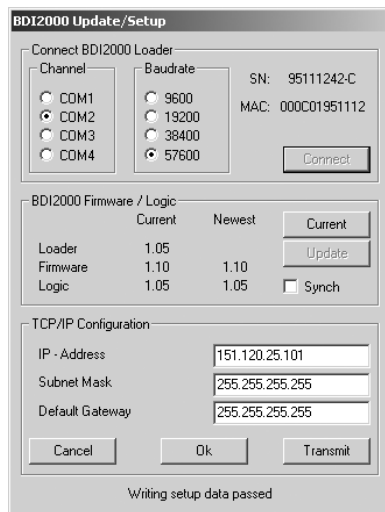

dialog box «BDI2000 Update/Setup»

The following options allow you to check or update the BDI firmware and logic and to set the network parameters:

- Channel Select the communication port where the BDI2000 is connected during this setup session.
- Baudrate Select the baudrate used to communicate with the BDI2000 loader during this setup session.
- Connect Click on this button to establish a connection with the BDI2000 loader. Once connected, the BDI2000 remains in loader mode until it is restarted or this dialog box is closed.
- Current Press this button to read back the current loaded BDI2000 software and logic versions. The current loader, firmware and logic version will be displayed.
- Update This button is only active if there is a newer firmware or logic version present in the execution directory of the BDI setup software. Press this button to write the new firmware and/or logic into the BDI2000 flash memory / programmable logic.

Synch	Because some older V2 ColdFire cores (e.g. MCF5272) need synchronous signals at the BDM interface, the BDI uses a different logic for this cores. Check this box only if your target is a MCF5204, MCF5206, MCF5206e or MCF5272. The BDI automatically selects the correct JEDEC file. Make sure that there is the correct logic loaded for the target CPU you are using.
IP Address	Enter the IP address for the BDI2000. Use the following format: xxx.xxx.xxx.xxx.g.151.120.25.101 Ask your network administrator for assigning an IP address to this BDI2000. Every BDI2000 in your network needs a different IP address.
Subnet Mask	Enter the subnet mask of the network where the BDI is connected to. Use the following format: xxx.xxx.xxx.xxx.g.255.255.255.0 A subnet mask of 255.255.255.255 disables the gateway feature. Ask your network administrator for the correct subnet mask.
Default Gateway	Enter the IP address of the default gateway. Ask your network administrator for the correct gateway IP address. If the gateway feature is disabled, you may enter 255.255.255.255 or any other value..
Transmit	Click on this button to store the network configuration in the BDI2000 flash memory.

In rare instances you may not be able to load the firmware in spite of a correctly connected BDI (error of the previous firmware in the flash memory). **Before carrying out the following procedure, check the possibilities in Appendix «Troubleshooting».** In case you do not have any success with the tips there, do the following:

- Switch OFF the power supply for the BDI and open the unit as described in Appendix «Maintenance»
- Place the jumper in the «**INIT MODE**» position
- Connect the power cable or target cable if the BDI is powered from target system
- Switch ON the power supply for the BDI again and wait until the LED «MODE» blinks fast
- Turn the power supply OFF again
- Return the jumper to the «**DEFAULT**» position
- Reassemble the unit as described in Appendix «Maintenance»

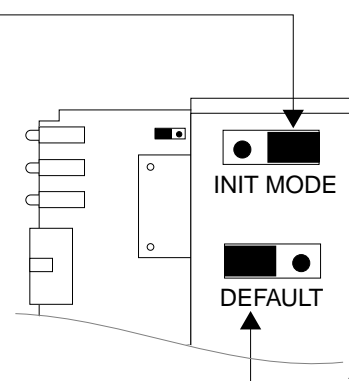

3 Init List

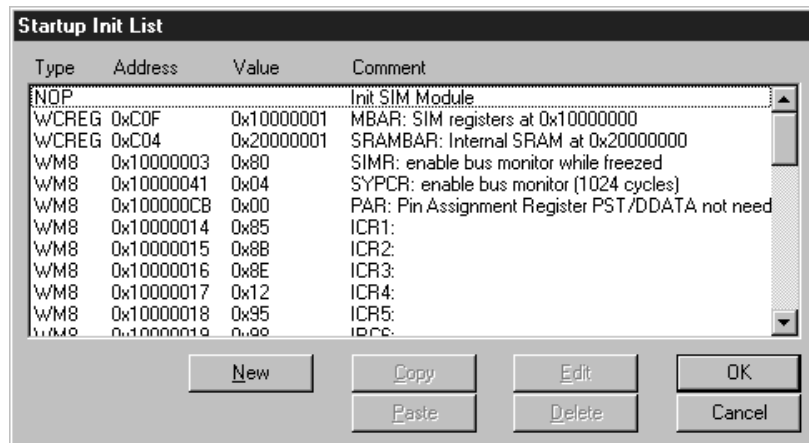

dialog box «Startup Init List»

In order to prepare the target for debugging, you can define an Initialization List. This list is stored in the Flash memory of the BDI2000 and worked through every time the target comes out of reset. Use it to get the target operational after a reset. The memory system is usually initialized through this list. After processing the init list, the RAM used to download the application must be accessible.

Use on-line help (F1) and the supplied configuration examples on the distribution disk to get more information about the init list.

Special BDI Configuration Registers:

In order to change some special configuration parameters of the BDI, the WCREG entry in the init list is used. Control register numbers greater than 0x8000 are used to set BDI internal registers:

- 8001 This entry in the init list allows to define a delay time (in ms) the BDI inserts between releasing the reset line and starting communicating with the target. This delay is necessary when a target needs some wake-up time after a reset.
- 8002 This entry in the init list allows to define a time (in ms) the BDI asserts the hardware reset signal. By default the reset signal is asserted for about 1ms.

4 BDI working modes

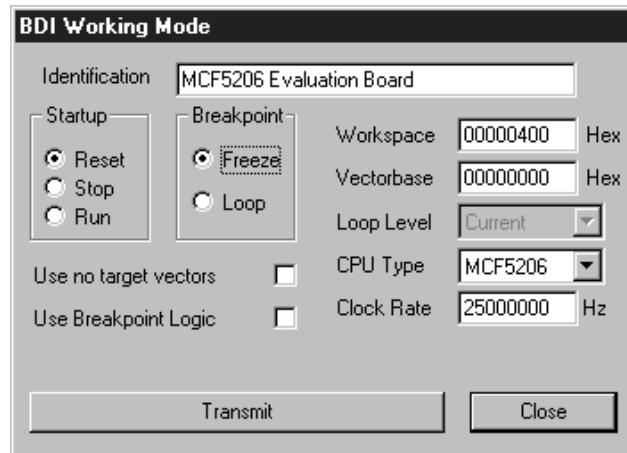

dialog box «BDI Working Mode»

With this dialog box you can define how the BDI interacts with the target system.

Identification	Enter a text to identify this setup. This text can be read by the debugger with the appropriate Command.
Startup	Startup mode defines how the BDI interacts with the target processor after reset or power up. The options RESET, STOP or RUN can be selected.
Breakpoint	Breakpoint mode defines how breakpoints are processed. The target processor may be frozen (FREEZED option) or may be set to loop in an exception procedure (LOOP option) while the application software is halted.
Workspace	In all configurations except when «Use no target vectors» is activated, BDI needs some target memory space. Enter here the start address of this memory area. A maximum of 512 bytes is needed.
Vector base	The BDI needs to know where the vector table is located. Enter here the start address of the vector table. This address is automatically loaded into the VBR register at startup time. The application should not change the VBR unless «Use no target vectors» is selected.
Loop Level	Selects the priority level (interrupt priority mask) the application uses when halted in LOOP mode. A level of 7 disables all interrupts when the application is halted. The value CURRENT(default) means, the application loops with the level currently active at the point where it is stopped.
CPU Type	Select the appropriate CPU type.
CPU Clock Rate ...	Enter the clock rate which the target CPU runs, after BDI has worked through the init list. BDI selects the BDM communication speed based on this parameter. If this parameter selects a CPU clock rate that is higher than the real clock, BDM communication may fail. When selecting a clock rate slower than possible, BDM communication still works but not as fast as possible.

Use no target vectors	Check this switch if the BDI should not use any RAM or vectors in the target system. This option is only enabled when FREEZED is selected as breakpoint mode. This mode is suitable for testing new hardware or debugging custom exception routines.
Use Breakpoint Logic	This switch defines how instruction breakpoints are implemented. When not checked (default), instruction breakpoints are set as requested by the debugger (Software or Hardware breakpoints). When checked, the BDI uses always hardware breakpoints. This is useful when the attached debugger does not support hardware break-points.

4.1 Startup Mode

Startup mode defines how the BDI interacts with the target system after a reset or power up sequence.

4.1.1 Startup mode RESET

In this mode no ROM is required on the target system. The necessary initialization is done by the BDI with the programmed init list. The following steps are executed by the BDI after system reset or system power up:

- RESET and BKPT are activated on the target system.
- RESET is deactivated and the target system changes to background debug mode.
- The BDI works through the initialization list and writes to the corresponding addresses.
- Depending on the break mode, the necessary vectors are set and help code is written into the RAM on the target system.

The RESET mode is the standard working mode. Other modes are used in special cases (i.e. applications in ROM, special requirements on the reset sequence...).

4.1.2 Startup Mode STOP

In this mode the initialization code is in a ROM on the target system. The code in this ROM handles base initialization and sets the stackpointer. At the end of the code, the initialization program enters an endless loop until it is interrupted by the BDI. This mode is intended for special requirements on the reset sequence or, if, for example, separate hardware needs to be initialized immediately.

In this mode the following steps are executed by the BDI after system reset or power up:

- RESET and BKPT are activated on the target system.
- RESET is deactivated and the target system changes to background debug mode.
- The target CPU is started (the target starts at the address fetched when reading the start vector at address 0).
- The target system is working through the application code.
- After 2 seconds, BKPT is activated and the target system changes to background debug mode.
- The BDI works through the initialization list and writes the corresponding addresses.
- Depending on the break mode, the necessary vectors are set and support code is written into the RAM on the target system.

4.1.3 Startup mode RUN

This mode is used to debug applications which are already stored in ROM. The application is started normally and is stopped by the BDI as soon as the debugger connects to the BDI.

In this mode, the following steps are executed by the BDI after system reset or power up:

- RESET and BKPT are activated on the target system.
- RESET is deactivated and the target system changes to background debug mode.
- The target CPU is started (the target starts at the address fetched when reading the start vector at address 0).
- The target system is executing the application code.
- The application runs until the debugger stops the execution.
- BKPT is activated on the target system, and the target system changes to background debug mode.
- Depending on the break mode, the necessary vectors are set and help code is written into the RAM on the target system.

4.2 Breakpoint Mode

The use of software breakpoints is only possible if the application code is stored in RAM (not in ROM) on the target system. Depending on the selected breakpoint mode, breakpoint and single step functions are implemented total differently.

4.2.1 Breakpoint Mode FREEZED

In this mode breakpoints are implemented by replacing application code with the HALT instruction. All the time the application is halted (i.e. caused by a breakpoint) the target processor remains frozen.

Single step is implemented by setting the appropriate bits (SSM, IPI) in the Debug Configuration/Status register and starting the CPU. Interrupts are ignored and debug mode is reentered after executing exact one instruction.

4.2.2 Breakpoint Mode LOOP

In this mode breakpoints are implemented by replacing application code with a ILLEGAL instruction. A stopped application loops within an exception procedure. The target processor is never frozen. The priority level used when looping in the exception procedure can be defined using the option «Loop Level». If you want to stop the whole application use Loop Level 7. If only the current task should be stopped, use Loop Level CURRENT.

Single step is implemented by setting the Trace bit in the processor status register. So a single step steps always over the current instruction. If interrupts are pending, they are served first without stopping the target processor.

The Loop mode is suitable when debugging real-time applications which can not be frozen, because external interrupt must be handled even when an application task is stopped at a breakpoint.

The following diagram shows the used universal exception procedure for ColdFire targets. May be this helps you to understand how BDI works in LOOP mode.

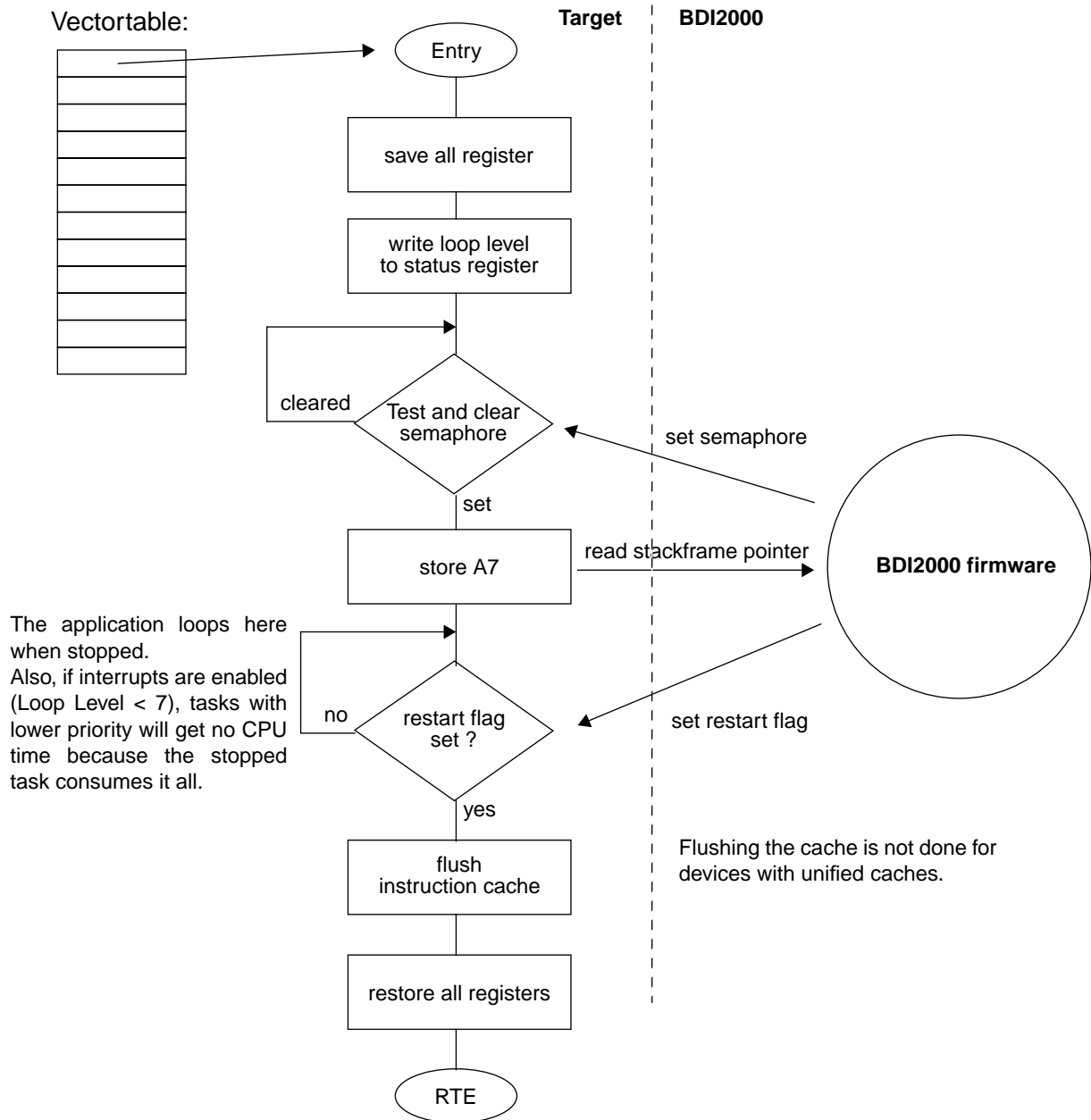

The ColdFire is never frozen because it is possible to access target memory via the BDM interface while the CPU is running.

4.3 Workspace

Depending on the working mode, the BDI needs some RAM in the target system. The following table shows how much RAM is used in the different modes.

Mode	Workspace (Bytes)	Remark
RESET/FREEZED	4	needed to trap the exceptions
STOP/FREEZED	4	needed to trap the exceptions
RUN/FREEZED	4	needed to trap the exceptions
RESET/LOOP	512	used for standard exception procedure and the initial (supervisor) stack
STOP/LOOP	256	used for standard exception procedure
RUN/LOOP	256	used for standard exception procedure

Vectors in RUN mode:

When RUN mode is selected, only the vectors 0... 24 are initialized when the application is halted for the first time .

5 Specifications

Operating Voltage Limiting	5 VDC ± 0.25 V
Power Supply Current	typ. 500 mA max. 1000 mA
RS232 Interface: Baud Rates	9'600, 19'200, 38'400, 57'600, 115'200
Data Bits	8
Parity Bits	none
Stop Bits	1
Network Interface	10 BASE-T
Serial Transfer Rate between BDI and Target	up to 16 Mbit/s
Supported target voltage	1.8 – 5.0 V (3.0 – 5.0 V with Rev. B)
Operating Temperature	+ 5 °C ... +60 °C
Storage Temperature	-20 °C ... +65 °C
Relative Humidity (noncondensing)	<90 %rF
Size	190 x 110 x 35 mm
Weight (without cables)	420 g
Host Cable length (RS232)	2.5 m

Specifications subject to change without notice

6 Warranty

ABATRON Switzerland warrants the physical diskette, cable, BDI2000 and physical documentation to be free of defects in materials and workmanship for a period of 24 months following the date of purchase when used under normal conditions.

In the event of notification within the warranty period of defects in material or workmanship, ABATRON will replace defective diskette, cable, BDI2000 or documentation. The remedy for breach of this warranty shall be limited to replacement and shall not encompass any other damages, including but not limited loss of profit, special, incidental, consequential, or other similar claims.

ABATRON Switzerland specifically disclaims all other warranties- expressed or implied, including but not limited to implied warranties of merchantability and fitness for particular purposes - with respect to defects in the diskette, cable, BDI2000 and documentation, and the program license granted herein, including without limitation the operation of the program with respect to any particular application, use, or purposes. In no event shall ABATRON be liable for any loss of profit or any other commercial damage, including but not limited to special, incidental, consequential, or other damages.

Failure in handling which leads to defects are not covered under this warranty. The warranty is void under any self-made repair operation except exchanging the fuse.

Appendices

A Troubleshooting

Problem

The firmware can not be loaded.

Possible reasons

- The BDI is not correctly connected with the target system (see chapter 2).
- The power supply of the target system is switched off or not in operating range (4.75 VDC ... 5.25 VDC) --> MODE LED is OFF or RED
- The built in fuse is damaged --> MODE LED is OFF
- The BDI is not correctly connected with the Host (see chapter 2).
- A wrong communication port (Com 1...Com 4) is selected.

Problem

No working with the target system (loading firmware is ok).

Possible reasons

- Wrong pin assignment (BDM/JTAG connector) of the target system (see chapter 2).
- Target system initialization is not correctly --> enter an appropriate target initialization list.
- An incorrect IP address was entered (BDI2000 configuration)
- BDM/JTAG signals from the target system are not correctly (short-circuit, break, ...).
- The target system is damaged.

Problem

Network processes do not function (loading the firmware was successful)

Possible reasons

- The BDI2000 is not connected or not correctly connected to the network (LAN cable or media converter)
- An incorrect IP address was entered (BDI2000 configuration)

B Maintenance

The BDI needs no special maintenance. Clean the housing with a mild detergent only. Solvents such as gasoline may damage it.

If the BDI is connected correctly and it is still not responding, then the built in fuse might be damaged (in cases where the device was used with wrong supply voltage or wrong polarity). To exchange the fuse or to perform special initialization, please proceed according to the following steps:



Observe precautions for handling (Electrostatic sensitive device)
Unplug the cables before opening the cover.
Use exact fuse replacement (Microfuse MSF 1.6 AF).

1

1.1 Unplug the cables

2

2.1 Remove the two plastic caps that cover the screws on target front side (e.g. with a small knife)

2.2 Remove the two screws that hold the front panel

3

3.1 While holding the casing, remove the front panel and the red elastic sealing

4

4.1 While holding the casing, slide carefully the print in position as shown in figure below

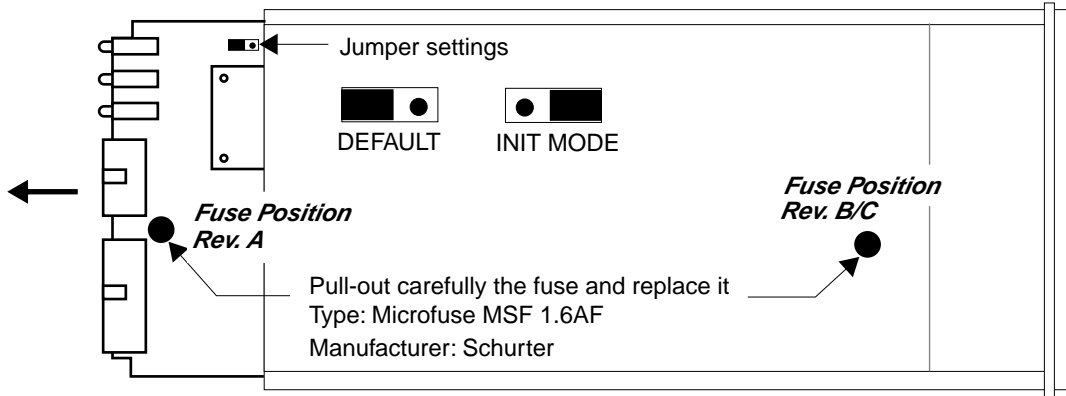

5

Reinstallation

5.1 Slide back carefully the print. Check that the LEDs align with the holes in the back panel.

5.2 Push carefully the front panel and the red elastic sealing on the casing. Check that the LEDs align with the holes in the front panel and that the position of the sealing is as shown in the figure below.

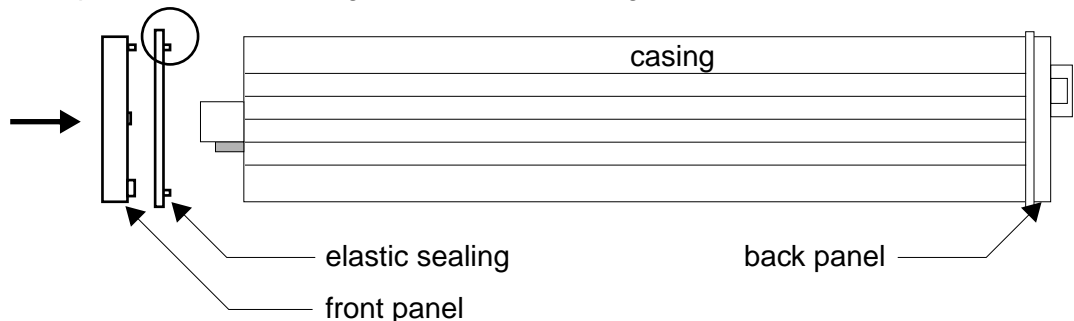

5.3 Mount the screws (do not overtighten it)

5.4 Mount the two plastic caps that cover the screws

5.5 Plug the cables



**Observe precautions for handling (Electrostatic sensitive device)
Unplug the cables before opening the cover.
Use exact fuse replacement (Microfuse MSF 1.6 AF).**

C Trademarks

All trademarks are property of their respective holders.