

*bedi*CW

JTAG debug interface for CodeWarrior™ Debugger

PowerPC 6xx/7xx/82xx/7400/7410



User Manual

Manual Version 1.07 for BDI2000



© 1999-2006 ABATRON AG

1 Introduction	3
1.1 BDI2000.....	3
2 Installation	4
2.1 Connecting the BDI2000 to Target.....	4
2.1.1 Changing Target Processor Type	6
2.2 Connecting the BDI2000 to Power Supply.....	7
2.3 Status LED «MODE»	8
2.4 Connecting the BDI2000 to the Host	9
2.4.1 Serial line communication	9
2.4.2 Ethernet communication	10
2.5 Installation of the Configuration Software	11
2.6 Configuration	12
2.6.1 BDI2000 Setup/Update	12
3 Init List.....	14
4 BDI working modes	16
4.1 Startup Mode	17
4.1.1 Startup mode RESET	17
4.1.2 Startup Mode STOP	17
4.1.3 Startup mode RUN.....	17
5 Working with CodeWarrior.....	18
5.1 Setup	18
6 Telnet Interface	19
7 Specifications	20
8 Environmental notice	21
9 Declaration of Conformity (CE).....	21
10 Warranty	22
 Appendices	
A Troubleshooting	23
B Maintenance	24
C Trademarks	26

1 Introduction

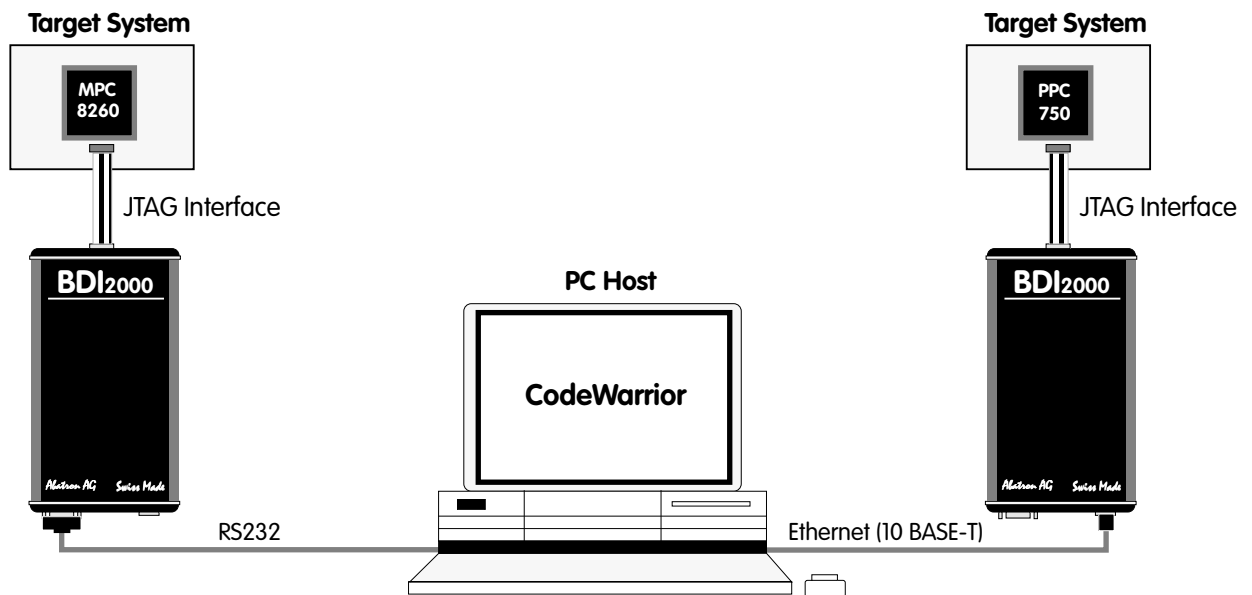

The BDI2000 adds JTAG based debug features to the CodeWarrior debugger environment from Metrowerks. With the BDI2000, you control and monitor the microcontroller solely through the stable on-chip debugging services. You won't waste time and target resources with a software ROM monitor, and you eliminate the cabling problems typical of ICE's. This combination runs even when the target system crashes and allows developers to continue investigating the cause of the crash.

A RS232 interface with a maximum of 115 kBaud and a 10Base-T Ethernet interface is available for the host interface.

The configuration software is used to update the firmware and to configure the BDI2000 so it works with the CodeWarrior debugger.

1.1 BDI2000

The BDI2000 is a processor system in a small box. It implements the interface between the JTAG pins of the target CPU and a 10Base-T Ethernet / RS232 connector. The firmware and the programmable logic of the BDI2000 can be updated by the user with a simple Windows based configuration program. The BDI2000 supports 1.8 – 5.0 Volts target systems (3.0 – 5.0 Volts target systems with Rev. B).

2 Installation

2.1 Connecting the BDI2000 to Target

The cable to the target system is a 16 pin flat ribbon cable. In case where the target system has an appropriate connector, the cable can be directly connected. The pin assignment is in accordance with the PowerPC COP connector specification.



In order to ensure reliable operation of the BDI (EMC, runtimes, etc.) the target cable length must not exceed 20 cm (8").

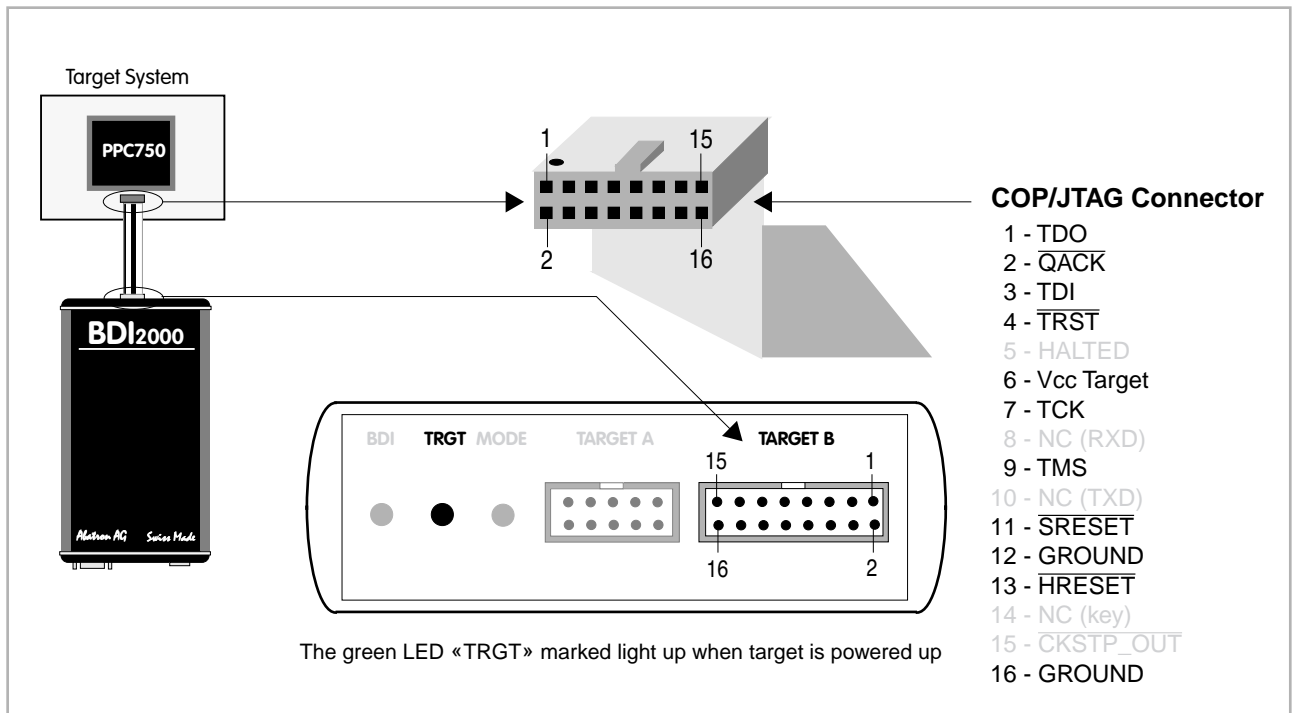

For BDI TARGET B connector signals see table on next page.

BDI TARGET B Connector Signals:

Pin	Name	Description
1	TDO	JTAG Test Data Out This input to the BDI2000 connects to the target TDO pin.
2	$\overline{\text{QACK}}$	QACK This output of the BDI2000 connects to the target QACK pin. By default this pin is not driven by the BDI2000. With an entry in the init liste it can be forced low.
3	TDI	JTAG Test Data In This output of the BDI2000 connects to the target TDI pin.
4	$\overline{\text{TRST}}$	JTAG Test Reset This output of the BDI2000 resets the JTAG TAP controller on the target.
5	IN0	General purpose Input This input to the BDI2000 connects to the target HALTED pin. Currently not used.
6	Vcc Target	1.8 – 5.0V: This is the target reference voltage. It indicates that the target has power and it is also used to create the logic-level reference for the input comparators. It also controls the output logic levels to the target. It is normally fed from Vdd I/O on the target board. 3.0 – 5.0V with Rev. B : This input to the BDI2000 is used to detect if the target is powered up. If there is a current limiting resistor between this pin and the target Vdd, it should be 100 Ohm or less.
7	TCK	JTAG Test Clock This output of the BDI2000 connects to the target TCK pin.
8	<reseved>	
9	TMS	JTAG Test Mode Select This output of the BDI2000 connects to the target TMS line.
10	<reseved>	
11	$\overline{\text{SRESET}}$	Soft-Reset This open collector output of the BDI2000 connects to the target SRESET pin.
12	GROUND	System Ground
13	$\overline{\text{HRESET}}$	Hard-Reset This open collector output of the BDI2000 connects to the target HRESET pin.
14	<reseved>	
15	IN1	General purpose Input This input to the BDI2000 connects to the target CKSTP_OUT pin. Currently not used.
16	GROUND	System Ground

2.1.1 Changing Target Processor Type

Before you can use the BDI2000 with an other target processor type (e.g. CPU32 <--> PPC), a new setup has to be done (see Appendix A). During this process the target cable must be disconnected from the target system. The BDI2000 needs to be supplied with 5 Volts via the BDI OPTION connector (Version A) or via the POWER connector (Version B). For more information see chapter 2.2.1 «External Power Supply».



To avoid data line conflicts, the BDI2000 must be disconnected from the target system while programming the logic for an other target CPU.

2.2 Connecting the BDI2000 to Power Supply

The BDI2000 needs to be supplied with 5 Volts (max. 1A) via the POWER connector. The available power supply from Abatron (option) or the enclosed power cable can be directly connected. In order to ensure reliable operation of the BDI2000, keep the power supply cable as short as possible.



For error-free operation, the power supply to the BDI2000 must be between 4.75V and 5.25V DC. **The maximal tolerable supply voltage is 5.25 VDC. Any higher voltage or a wrong polarity might destroy the electronics.**

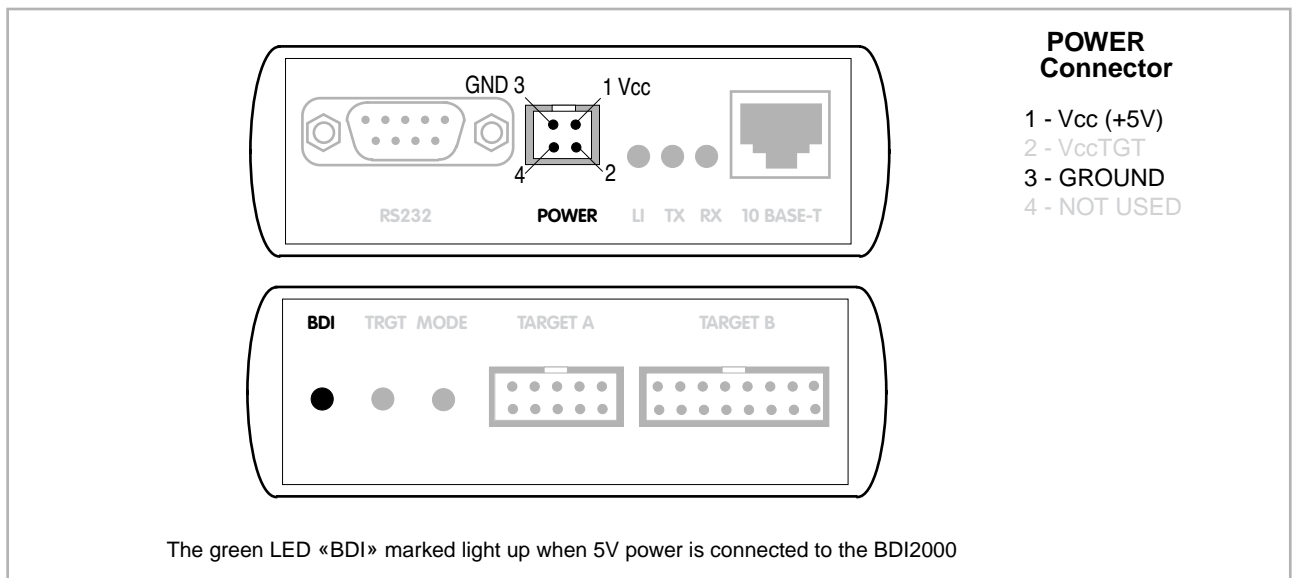

Please switch on the system in the following sequence:

- 1 --> external power supply
- 2 --> target system

2.3 Status LED «MODE»

The built in LED indicates the following BDI states:

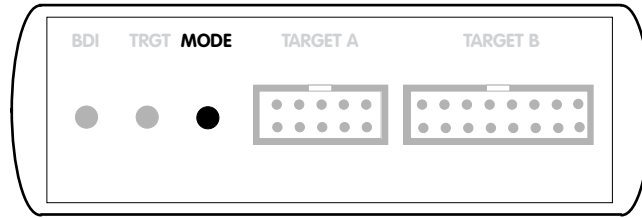

MODE LED	BDI STATES
OFF	The BDI is ready for use, the firmware is already loaded.
ON	The power supply for the BDI2000 is < 4.75VDC.
BLINK	The BDI «loader mode» is active (an invalid firmware is loaded or loading firmware is active).

2.4 Connecting the BDI2000 to the Host

2.4.1 Serial line communication

The host is connected to the BDI through the serial interface (COM1...COM4). The communication cable between BDI and Host is a serial cable (RXD / TXD are crossed). There is the same connector pinout for the BDI and for the Host side (Refer to Figure below).

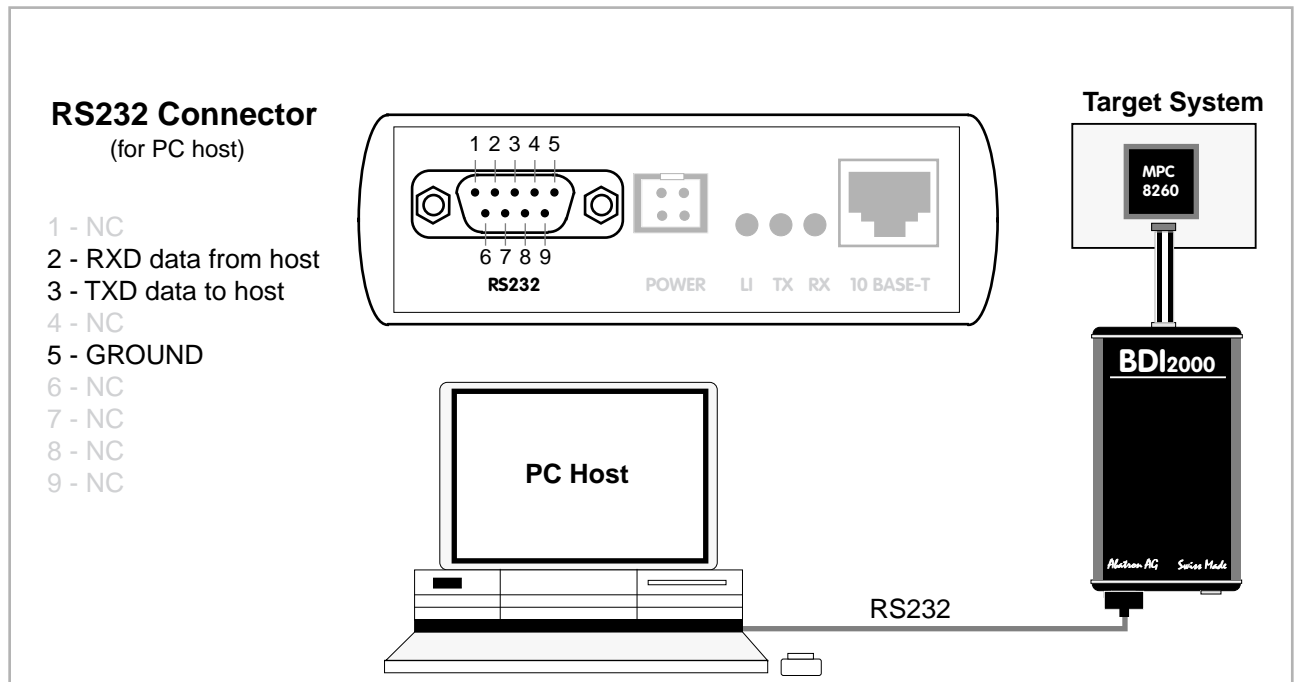

2.4.2 Ethernet communication

The BDI2000 has a built-in 10 BASE-T Ethernet interface (see figure below). Connect an UTP (Unshielded Twisted Pair) cable to the BDI2000. For thin Ethernet coaxial networks you can connect a commercially available media converter (BNC-->10 BASE-T) between your network and the BDI2000. Contact your network administrator if you have questions about the network.

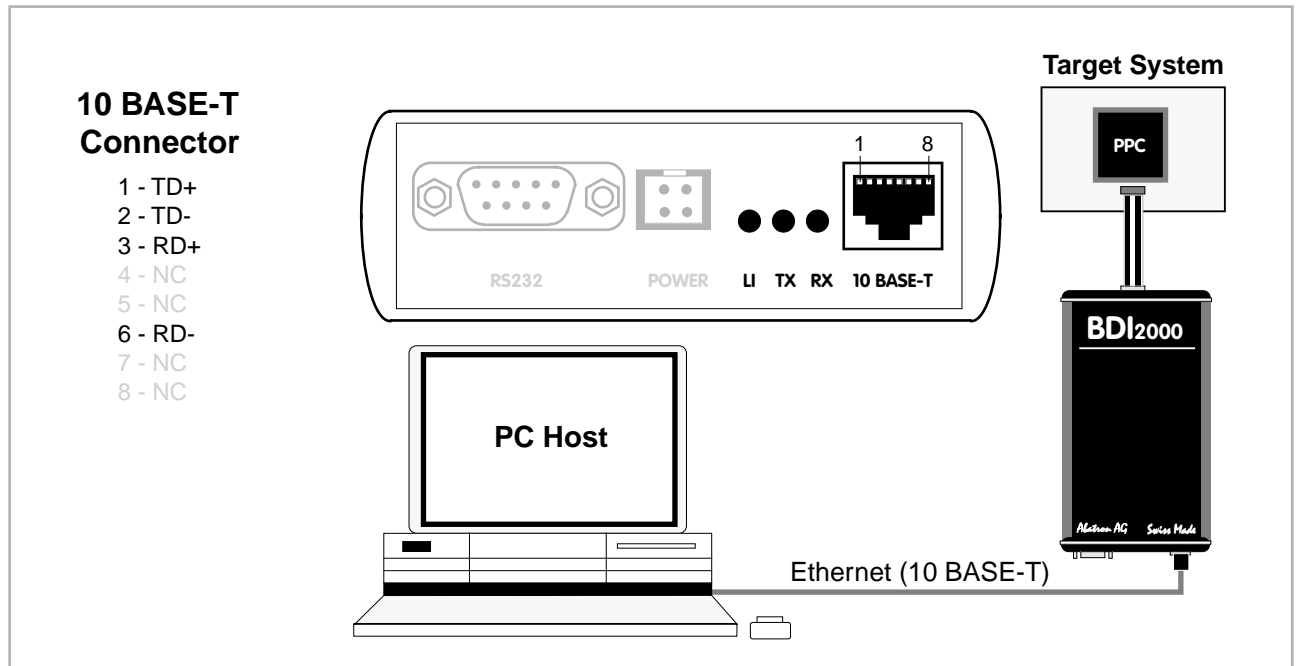

The following explains the meanings of the built-in LED lights:

LED	Name	Description
LI	Link	When this LED light is ON, data link is successful between the UTP port of the BDI2000 and the hub to which it is connected.
TX	Transmit	When this LED light BLINKS, data is being transmitted through the UTP port of the BDI2000
RX	Receive	When this LED light BLINKS, data is being received through the UTP port of the BDI2000

2.5 Installation of the Configuration Software

On the enclosed diskette you will find the BDI configuration software and the firmware required for the BDI. Copy all these files to a directory on your hard disk.

The following files are on the diskette:

b20cop.exe	Configuration program
b20cop.hlp	Helpfile for the configuration program
b20cop.cnt	Help contents file
b20copfw.xxx	Firmware for BDI2000 for COP targets (PPC6xx/7xx/82xx)
copjed20.xxx	JEDEC file for BDI2000 (Rev. B) logic device programming
copjed21.xxx	JEDEC file for BDI2000 (Rev. C) logic device programming
bdiifc32.dll	BDI Interface DLL
*.bdi	Configuration Examples

Example of an installation process:

- Copy the entire contents of the enclosed diskette into a directory on the hard disk.
- You may create a new shortcut to the b20cop.exe configuration program.
- Copy the BDI interface DLL to ...\\CodeWarrior\\Bin\\Plugins\\Support\\Abatron\\bdiifc32.dll

2.6 Configuration

Before you can use the BDI together with the debugger, the BDI must be configured. Use the *SETUP* menu and follow the steps listed below:

- Load or update the firmware / logic, store IP address --> *Firmware*
- Set the communication parameters between Host and BDI --> *Communication*
- Setup an initialization list for the target processor --> *Initlist*
- Select the working mode --> *Mode*
- Transmit the configuration to the BDI --> *Mode Transmit*

For information about the dialogs and menus use the help system (F1).

2.6.1 BDI2000 Setup/Update

First make sure that the BDI is properly connected (see Chapter 2.1 to 2.4). The BDI must be connected via RS232 to the Windows host.



To avoid data line conflicts, the BDI2000 must be disconnected from the target system while programming the logic for an other target CPU (see Chapter 2.1.1).

The following dialogbox is used to check or update the BDI firmware and logic and to set the network parameters.

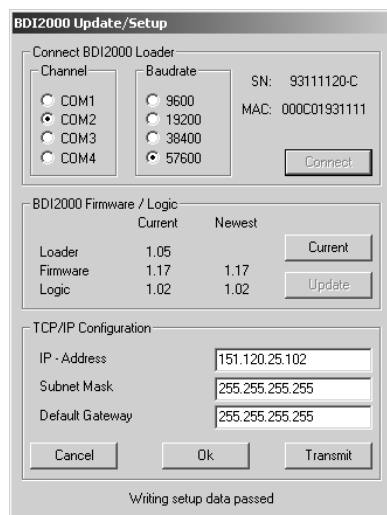

dialog box «BDI2000 Update/Setup»

The following options allow you to check or update the BDI firmware and logic and to set the network parameters:

- Channel Select the communication port where the BDI2000 is connected during this setup session.
- Baudrate Select the baudrate used to communicate with the BDI2000 loader during this setup session.

Connect	Click on this button to establish a connection with the BDI2000 loader. Once connected, the BDI2000 remains in loader mode until it is restarted or this dialog box is closed.
Current	Press this button to read back the current loaded BDI2000 software and logic versions. The current loader, firmware and logic version will be displayed.
Update	This button is only active if there is a newer firmware or logic version present in the execution directory of the BDI setup software. Press this button to write the new firmware and/or logic into the BDI2000 flash memory / programmable logic.
IP Address	Enter the IP address for the BDI2000. Use the following format: xxx.xxx.xxx.xx.e.g.151.120.25.101 Ask your network administrator for assigning an IP address to this BDI2000. Every BDI2000 in your network needs a different IP address.
Subnet Mask	Enter the subnet mask of the network where the BDI is connected to. Use the following format: xxx.xxx.xxx.xx.e.g.255.255.255.0 A subnet mask of 255.255.255.255 disables the gateway feature. Ask your network administrator for the correct subnet mask.
Default Gateway	Enter the IP address of the default gateway. Ask your network administrator for the correct gateway IP address. If the gateway feature is disabled, you may enter 255.255.255.255 or any other value..
Transmit	Click on this button to store the network configuration in the BDI2000 flash memory.

In rare instances you may not be able to load the firmware in spite of a correctly connected BDI (error of the previous firmware in the flash memory). **Before carrying out the following procedure, check the possibilities in Appendix «Troubleshooting».** In case you do not have any success with the tips there, do the following:

- Switch OFF the power supply for the BDI and open the unit as described in Appendix «Maintenance»
- Place the jumper in the «**INIT MODE**» position
- Connect the power cable or target cable if the BDI is powered from target system
- Switch ON the power supply for the BDI again and wait until the LED «MODE» blinks fast
- Turn the power supply OFF again
- Return the jumper to the «**DEFAULT**» position
- Reassemble the unit as described in Appendix «Maintenance»

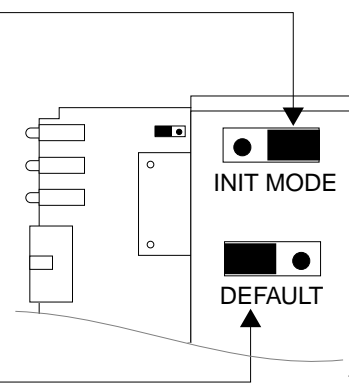

3 Init List

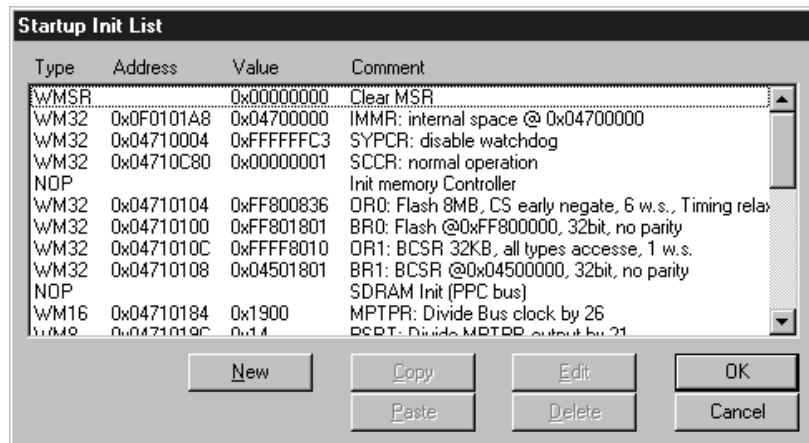

dialog box «Startup Init List»

In order to prepare the target for debugging, you can define an Initialization List. This list is stored in the Flash memory of the BDI2000 and worked through every time the target comes out of reset. Use it to get the target operational after a reset. The memory system is usually initialized through this list. After processing the init list, the RAM used to download the application must be accessible.

Use on-line help (F1) and the supplied configuration examples on the distribution disk to get more information about the init list.

You may also use the debuggers feature to setup the hardware (chip initialization file).

Special BDI Configuration Registers:

In order to change some special configuration parameters of the BDI, the SPR entry in the init list is used. Normal PPC SPR's covers a range from 0 to 1023. Other SPR's are used to set BDI internal registers:

- 8001 For slow memory it may be necessary to increase the number of clocks used to execute a memory access cycle. If for example you cannot access boot ROM content with the default configuration of your memory controller, define additional memory access clocks with this SPR number in the init list. Usual values are in the range 1000 - 4000 (0x400 - 0x1000).
- 8002 Defines an alternate boot address. Normally a PPC boots from 0xFFF00100. A MPC8260 has also the option to boot from 0x00000100. The BDI needs to know the boot address in order to set the correct hardware breakpoint during startup..
- 8003 Defines the base address of the L2 cache private memory. Because L2 cache private memory cannot be accessed directly via JTAG, the BDI loads some support code into the workspace and uses it to access this memory range. Therefore a workspace is necessary to access this memory range.
- 8004 Defines the size of the L2 cache private memory in bytes (e.g. 0x100000 for 1Mbyte).

- 8006 Write to this special register with a value of 1, if the BDI should use the alternate single step mode. The alternate mode does not use the trace bit (MSR[SE]) to implement single stepping. It uses always a hardware breakpoint (via IABR) on the next instruction to implement single stepping.
- 8007 Write to this special register with a value of 1, if the PPC core operates in 32-bit data bus mode.
- 8008 If the BDI should generate data parity bits when writing to memory, write to this special register with a value of 1.
- 8009 This entry in the init list allows to define a delay time (in ms) the BDI inserts between releasing the COP-HRESET line and starting communicating with the target. This init list entry may be necessary if COP-HRESET is delayed on its way to the PowerPC reset pin.
- 8010 If the BDI should forces the QACK pin (pin 2) on the COP connector low, write to this special register a value of 1. By default the QACK pin is not driven by the BDI. This option maybe useful for PPC750 and PPC7400 targets.

The BDI can also handle systems with multiple devices connected to the JTAG scan chain. In order to put the other devices into BYPASS mode and to count for the additional bypass registers, the BDI needs some information about the scan chain layout. Enter the number and total instruction register (IR) length of the devices present before the PowerPC chip. Enter the appropriate information also for the devices following the PowerPC chip.

- 8011 Number of JTAG devices connected before the PowerPC chip.
- 8012 Total IR length of the JTAG devices connected before the PowerPC chip
- 8013 Number of JTAG devices connected after the PowerPC chip
- 8014 Total IR length of the JTAG devices connected after the PowerPC chip

4 BDI working modes

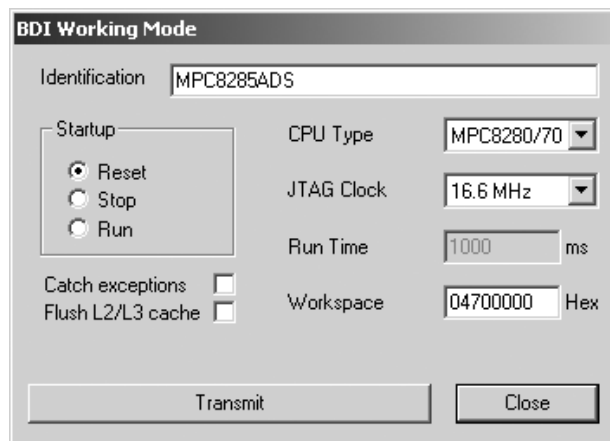

dialog box «BDI Working Mode»

With this dialog box you can define how the BDI interacts with the target system.

Identification	Enter a text to identify this setup.
Startup	Startup mode defines how the BDI interacts with the target processor after reset or power up. The options RESET, STOP or RUN can be selected.
CPU Type	Select the CPU type of the target system.
JTAG Clock	This option allows to select the used JTAG clock rate.
Run Time	When startup mode STOP is selected, this option allows to set the run time after reset in milliseconds until the target CPU is stopped. Values from 100 (0.1 sec) till 32000 (32 sec) are accepted.
Workspace	In order to speed up code download, enter the address of a free 256 byte RAM area. The BDI will install there some code that supports faster program download. A value of 0xFFFFFFFF disables the workspace. The BDI also needs this workspace to flush the data cache and to access L2 private memory.
Catch exceptions	Check this switch if the BDI should catch unhandled exception. Catching exceptions is only possible if the memory at address 0x00000100 to 0x00001FFF is writable and the vector table is mapped to 0x00000000 (MSR[IP] = 0).
Flush L2/L3 cache	Check this switch if the BDI should flush the cache before accessing memory. This is mainly useful if there is a L2/L3 cache present. If this switch is not set, the BDI uses L1 (L1/L2) cache coherent read and write accesses to target memory. Coherent access means, that the cache is directly read or written via COP if the appropriate cache line is valid. In order to flush the data cache, the BDI needs some workspace in target RAM to execute the flush code. Do not check this switch if there is only a L1 cache present. For 750FX/GX check this switch only if there is a L3 cache present.
Transmit	Click on this button to send the initialization list and the working mode to the BDI. This is normally the last step done before the BDI can be used with the debugging system.

4.1 Startup Mode

Startup mode defines how the BDI interacts with the target system after a reset or power up sequence.

4.1.1 Startup mode RESET

In this mode no ROM is required on the target system. The necessary initialization is done by the BDI with the programmed init list. The following steps are executed by the BDI after system reset or system power up:

- HRESET is activated on the target system.
- HRESET is deactivated and the target is forced into debug mode.
- The BDI works through the initialization list.

The RESET mode is the standard working mode. Other modes are used in special cases (i.e. applications in ROM, special requirements on the reset sequence...).

4.1.2 Startup Mode STOP

In this mode the initialization code is in a ROM on the target system. The code in this ROM handles base initialization. At the end of the code, the initialization program enters an endless loop until it is interrupted by the BDI. This mode is intended for special requirements on the reset sequence (e.g. loading a RAM based programmable logic device).

In this mode the following steps are executed by the BDI after system reset or power up:

- HRESET is activated on the target system.
- HRESET is deactivated and the target begins executing application code.
- After a delay (Run Time), the target is forced into debug mode.
- The BDI works through the initialization list.

4.1.3 Startup mode RUN

This mode is used to debug an application which is already stored in ROM. The application is started normally and will be stopped when the debugger is started.

In this mode, the following steps are executed by the BDI after system reset or power up:

- HRESET is activated on the target system.
- HRESET is deactivated and the target begins executing application code.
- The application runs until it is stopped by the debugger.

5 Working with CodeWarrior

5.1 Setup

Use the CodeWarrior "IDE Preferences" dialog box, section "Debugger -> Remote Connections", and setup the appropriate communication parameters for the "Abatron TCP/IP" and "Abatron Serial" connection.

Use the CodeWarrior "your project Settings" dialog box, section "Debugger -> Remote Debugging" and select either "Abatron TCP/IP" or "Abatron Serial".

6 Telnet Interface

A Telnet server is integrated within the BDI that can be accessed when the BDI is connected via ethernet to the host. It may help to investigate problems and allows access to target resources that can not directly be accessed by the debugger.

The following commands are available:

```

"MD      [<address>] [<count>]  display target memory as word (32bit)",
"MDD     [<address>] [<count>]  display target memory as double word (64bit)",
"MDH     [<address>] [<count>]  display target memory as half word (16bit)",
"MDB     [<address>] [<count>]  display target memory as byte (8bit)",
"MM      <addr> <value> [<cnt>]  modify word(s) (32bit) in target memory",
"MMD     <addr> <value> [<cnt>]  modify double word(s) (64bit) in target memory",
"MMH     <addr> <value> [<cnt>]  modify half word(s) (16bit) in target memory",
"MMB     <addr> <value> [<cnt>]  modify byte(s) (8bit) in target memory",
"MC      [<address>] [<count>]  calculates a checksum over a memory range",
"MV      verifies the last calculated checksum",
"RD      display general purpose registers",
"RDSPR  <number>                display special purpose register",
"RDSR   <number>                display segment register",
"RDVR   [<number>]              display vector register",
"RM      <number> <value>        modify general purpose or user defined register",
"RMSPR  <number> <value>        modify special purpose register",
"RMSR   <number> <value>        modify segment register",
"RMVR   <nbr><val val val val>    modify vector register (four 32bit values)",
"DCACHE <addr | set>            display L1 data cache content",
"L2CACHE <addr | set>           display L2 cache content (only 750FX/GX)",
"UPMR   <MxMR> <MDR> <addr>    read selected UPM array",
"BOOT   reset the BDI and reload the configuration",
"RESET  reset the target system",
"GO     [<pc>]                  set PC and start target system",
"TI     [<pc>]                  trace on instuction (single step)",
"TC     [<pc>]                  trace on change of flow",
"HALT   force target to enter debug mode",
"BI     <addr>                  set instruction hardware breakpoint",
"CI     [<id>]                  clear instruction hardware breakpoint(s)",
"BD     [R|W] <addr>            set data watchpoint via DABR",
"CD     [<id>]                  clear data watchpoint(s)",
"INFO   display information about the current state",
"DCMD   <direct command>       execute a BDI direct command (see manual)",
"HELP   display command list",
"QUIT   terminate the Telnet session"

```

7 Specifications

Operating Voltage Limiting	5 VDC ± 0.25 V
Power Supply Current	typ. 500 mA max. 1000 mA
RS232 Interface: Baud Rates	9'600, 19'200, 38'400, 57'600, 115'200
Data Bits	8
Parity Bits	none
Stop Bits	1
Network Interface	10 BASE-T
Serial Transfer Rate between BDI and Target	up to 16 Mbit/s
Supported target voltage	1.8 – 5.0 V (3.0 – 5.0 V with Rev. B)
Operating Temperature	+ 5 °C ... +60 °C
Storage Temperature	-20 °C ... +65 °C
Relative Humidity (noncondensing)	<90 %rF
Size	190 x 110 x 35 mm
Weight (without cables)	420 g
Host Cable length (RS232)	2.5 m

Specifications subject to change without notice

8 Environmental notice



Disposal of the equipment must be carried out at a designated disposal site.

9 Declaration of Conformity (CE)

DECLARATION OF CONFORMITY
This declaration is valid for following product:
Type of device: BDM/JTAG Interface
Product name: BDI2000
The signing authorities state, that the above mentioned equipment meets
the requirements for emission and immunity according to
EMC Directive 89/336/EEC
The evaluation procedure of conformity was assured according to the
following standards:
EN 50081-2
EN 50082-2
This declaration of conformity is based on the test report no.
QNL-E853-05-8-a of QUINEL, Zug, accredited according to EN 45001.
Manufacturer:
ABATRON AG
Stöckenstrasse 4
CH-6221 Rickenbach
Authority:

Max Vock
Marketing Director

Ruedi Dummermuth
Technical Director
Rickenbach, May 30, 1998

10 Warranty

ABATRON Switzerland warrants the physical diskette, cable, BDI2000 and physical documentation to be free of defects in materials and workmanship for a period of 24 months following the date of purchase when used under normal conditions.

In the event of notification within the warranty period of defects in material or workmanship, ABATRON will replace defective diskette, cable, BDI2000 or documentation. The remedy for breach of this warranty shall be limited to replacement and shall not encompass any other damages, including but not limited loss of profit, special, incidental, consequential, or other similar claims.

ABATRON Switzerland specifically disclaims all other warranties- expressed or implied, including but not limited to implied warranties of merchantability and fitness for particular purposes - with respect to defects in the diskette, cable, BDI2000 and documentation, and the program license granted herein, including without limitation the operation of the program with respect to any particular application, use, or purposes. In no event shall ABATRON be liable for any loss of profit or any other commercial damage, including but not limited to special, incidental, consequential, or other damages.

Failure in handling which leads to defects are not covered under this warranty. The warranty is void under any self-made repair operation except exchanging the fuse.

Appendices

A Troubleshooting

Problem

The firmware can not be loaded.

Possible reasons

- The BDI is not correctly connected with the target system (see chapter 2).
- The power supply of the target system is switched off or not in operating range (4.75 VDC ... 5.25 VDC) --> MODE LED is OFF or RED
- The built in fuse is damaged --> MODE LED is OFF
- The BDI is not correctly connected with the Host (see chapter 2).
- A wrong communication port (Com 1...Com 4) is selected.

Problem

No working with the target system (loading firmware is ok).

Possible reasons

- Wrong pin assignment (BDM/JTAG connector) of the target system (see chapter 2).
- Target system initialization is not correctly --> enter an appropriate target initialization list.
- An incorrect IP address was entered (BDI2000 configuration)
- BDM/JTAG signals from the target system are not correctly (short-circuit, break, ...).
- The target system is damaged.

Problem

Network processes do not function (loading the firmware was successful)

Possible reasons

- The BDI2000 is not connected or not correctly connected to the network (LAN cable or media converter)
- An incorrect IP address was entered (BDI2000 configuration)

B Maintenance

The BDI needs no special maintenance. Clean the housing with a mild detergent only. Solvents such as gasoline may damage it.

If the BDI is connected correctly and it is still not responding, then the built in fuse might be damaged (in cases where the device was used with wrong supply voltage or wrong polarity). To exchange the fuse or to perform special initialization, please proceed according to the following steps:



**Observe precautions for handling (Electrostatic sensitive device)
Unplug the cables before opening the cover.
Use exact fuse replacement (Microfuse MSF 1.6 AF).**

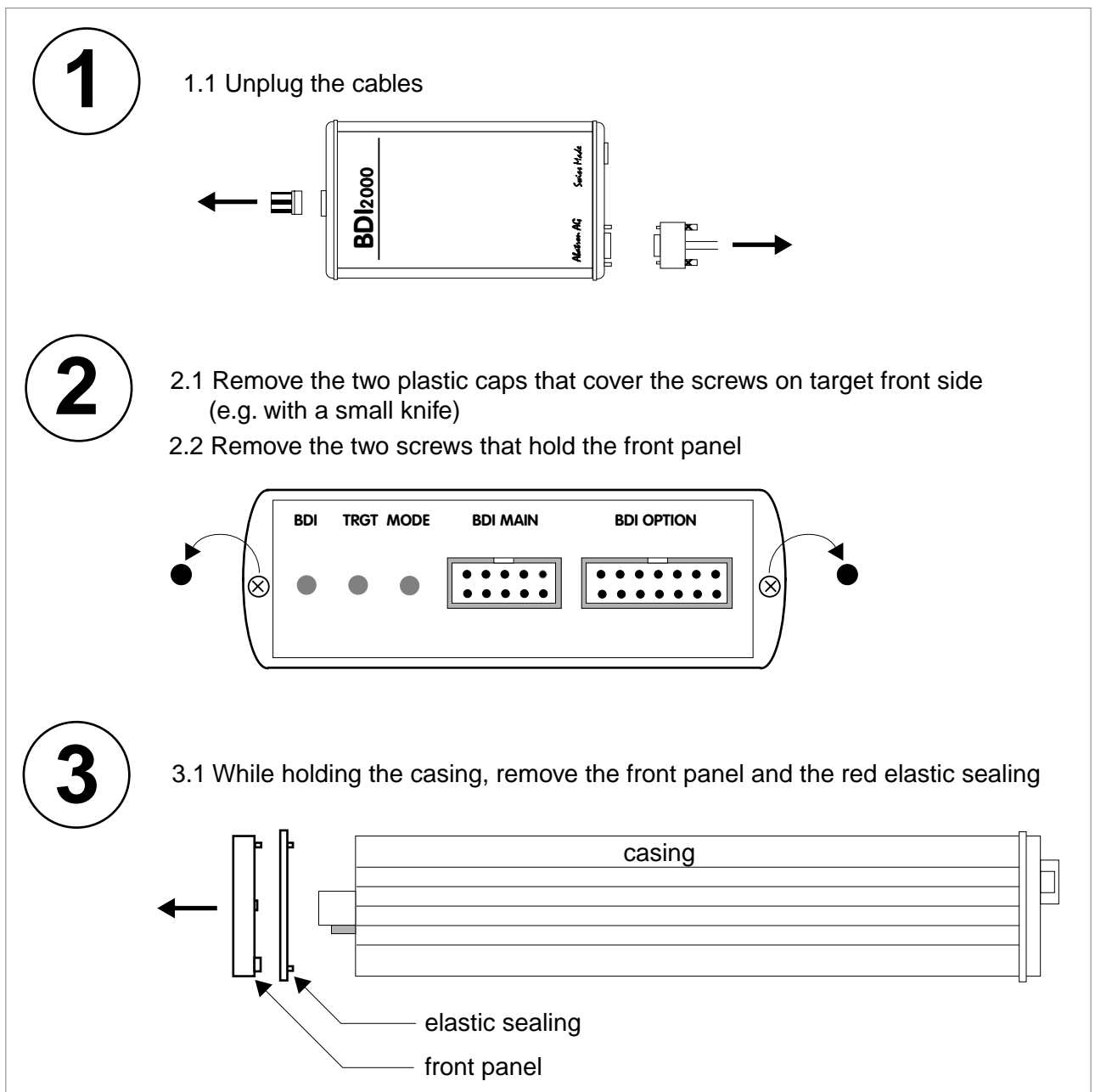

4

4.1 While holding the casing, slide carefully the print in position as shown in figure below

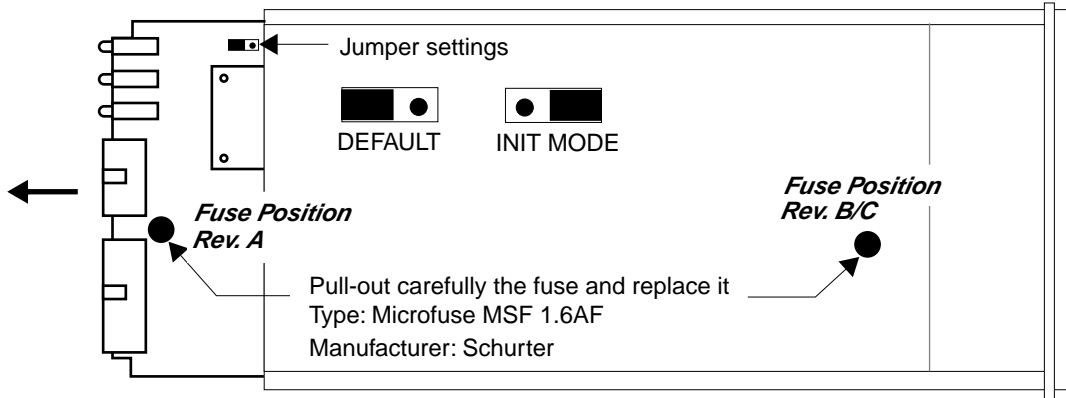

5

Reinstallation

5.1 Slide back carefully the print. Check that the LEDs align with the holes in the back panel.

5.2 Push carefully the front panel and the red elastic sealing on the casing. Check that the LEDs align with the holes in the front panel and that the position of the sealing is as shown in the figure below.

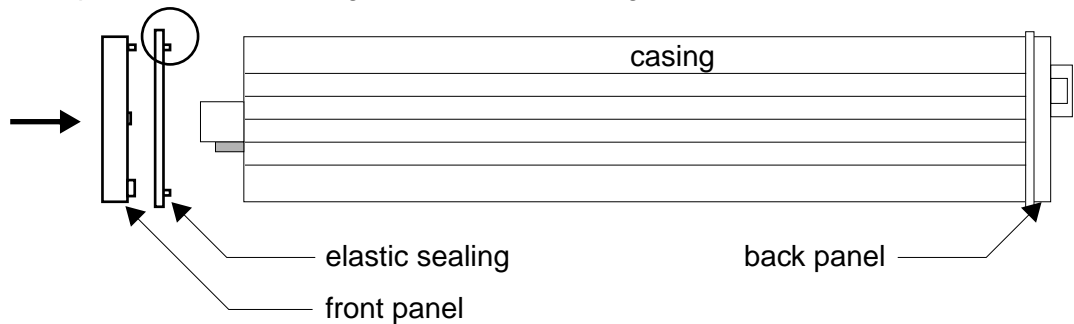

5.3 Mount the screws (do not overtighten it)

5.4 Mount the two plastic caps that cover the screws

5.5 Plug the cables



Observe precautions for handling (Electrostatic sensitive device)

Unplug the cables before opening the cover.

Use exact fuse replacement (Microfuse MSF 1.6 AF).

C Trademarks

All trademarks are property of their respective holders.