

*bdipro*®

for  
MIPS32



# User Manual

Manual Version 1.00 for BDI3000

---

|   |           |
|---|-----------|
| <b>1 Introduction .....</b>                     | <b>3</b>  |
| 1.1 BDI3000.....                                | 3         |
| 1.2 Functions .....                             | 4         |
| <b>2 Installation .....</b>                     | <b>5</b>  |
| 2.1 Connecting the BDI3000 to Target.....       | 5         |
| 2.2 Connecting the BDI3000 to Power Supply..... | 7         |
| 2.3 Status LED «MODE».....                      | 8         |
| 2.4 Connecting the BDI3000 to Host .....        | 9         |
| 2.4.1 Serial line communication .....           | 9         |
| 2.4.2 Ethernet communication .....              | 10        |
| 2.5 Installation of the bdiPro Software .....   | 11        |
| 2.6 Configuration .....                         | 11        |
| 2.6.1 BDI3000 Setup/Update .....                | 12        |
| <b>3 Specifications .....</b>                   | <b>14</b> |
| <b>4 Environmental notice .....</b>             | <b>15</b> |
| <b>5 Declaration of Conformity (CE).....</b>    | <b>15</b> |
| <b>6 Warranty .....</b>                         | <b>16</b> |
| <br><b>Appendices</b>                           |           |
| <b>A Troubleshooting .....</b>                  | <b>17</b> |
| <b>B Maintenance .....</b>                      | <b>18</b> |
| <b>C Trademarks .....</b>                       | <b>18</b> |

## 1 Introduction

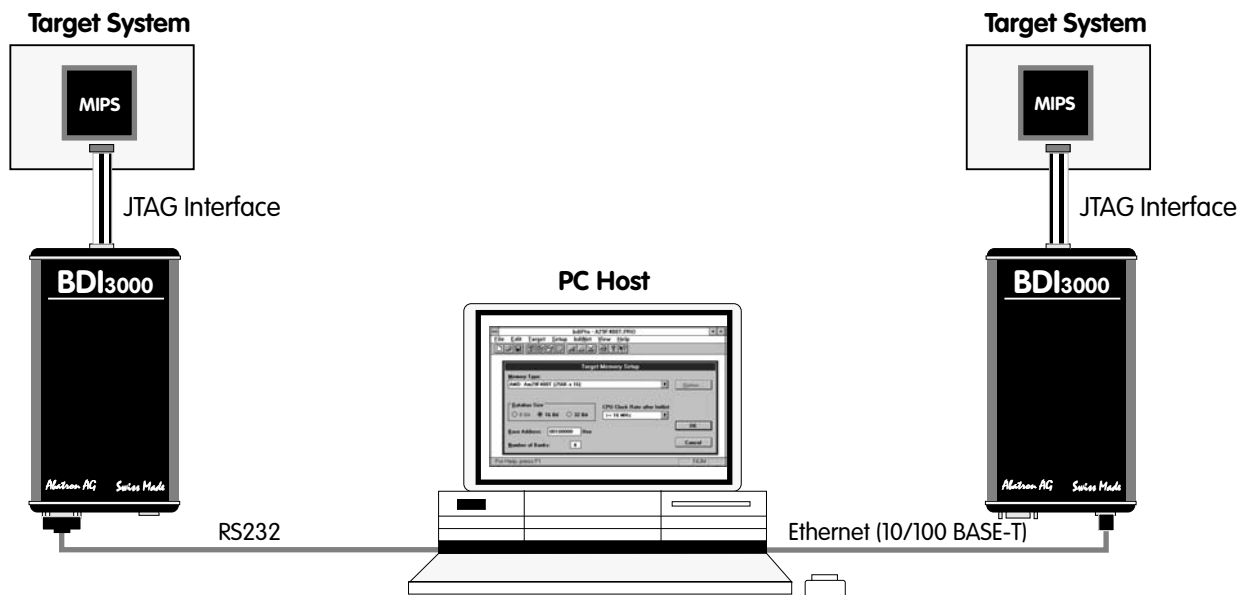

bdiPro is a powerful software package, allowing on-board programming with the BDI3000 from Abatron. bdiPro eliminates the inefficient, individual chip programming, particularly for surface-mounted designs. The unprogrammed memories can be soldered to the printed circuit board and programmed simultaneously on a just-in-time basis.

### 1.1 BDI3000

The BDI3000 is the main part of the bdiPro system. This small box implements the interface between the BDM/JTAG pins of the target processor and a 10/100Base-T Ethernet or RS232 connector. The firmware of the BDI3000 can be updated by the user with a simple Windows based configuration program. The BDI3000 supports 1.2 – 5.0 Volts target systems.

## 1.2 Functions

The bdiPro software provides the following functions:

|               |                         |  |
|---------------|-------------------------|--|
| <b>File</b>   | <i>Load/Save</i>        | • Save and recall user defined program sets  |
|               | <i>Print</i>            | • Print the active program set   |
|               | <i>Print Preview</i>    | • Display the active program set on the screen   |
|               | <i>Print Setup</i>      | • Select the printer and the printer connection  |
|               | <i>Print Comment</i>    | • Edit the headers and comment   |
| <b>Edit</b>   | <i>Load</i>             | • Load the program file (Binary, Motorola S-Record and Intel hex)  |
|               | <i>Store</i>            | • Store the local memory image in S-Record format  |
|               | <i>Dump</i>             | • Load the target system data into local memory  |
|               | <i>Edit</i>             | • Edit the local memory image  |
|               | <i>Clear</i>            | • Clear the local memory image   |
|               | <i>Fill</i>             | • Fill a local memory area with pattern  |
|               | <i>Checksum</i>         | • Calculation of checksum  |
| <b>Target</b> | <i>Erase</i>            | • Erase the target memory (all / sectors)  |
|               | <i>Program</i>          | • Program the target memory  |
|               | <i>Verify</i>           | • Compare the target system memory with local memory   |
| <b>Setup</b>  | <i>Communication</i>    | • Communication setup between the PC and the BDI   |
|               | <i>Firmware</i>         | • Load and verify the firmware   |
|               | <i>Target Memory</i>    | • Target memory setup (memory type and memory organisation)  |
|               | <i>Target Initlists</i> | • User configurable program sequences for target system initialization (clock, chip select...)<br><br>• If required, you can write special routines that runs before or after the program/erase process (pre-programming, post-programming / pre-erase, post-erase). |
| <b>Help</b>   |                         | • Information about menus and dialog boxes by pressing the F1 function key   |

## 2 Installation

### 2.1 Connecting the BDI3000 to Target

The cables to the target system are designed for the IDT RC32300 Development Boards (optional available: Part# 90070) and for EJTAG 2.5 compatible boards (enclosed). In case where the target system has the same connector layout, the cable (14 pin or 24 pin) can be directly connected.



In order to ensure reliable operation of the BDI (EMC, runtimes, etc.) the target cable length must not exceed 25 cm (10").

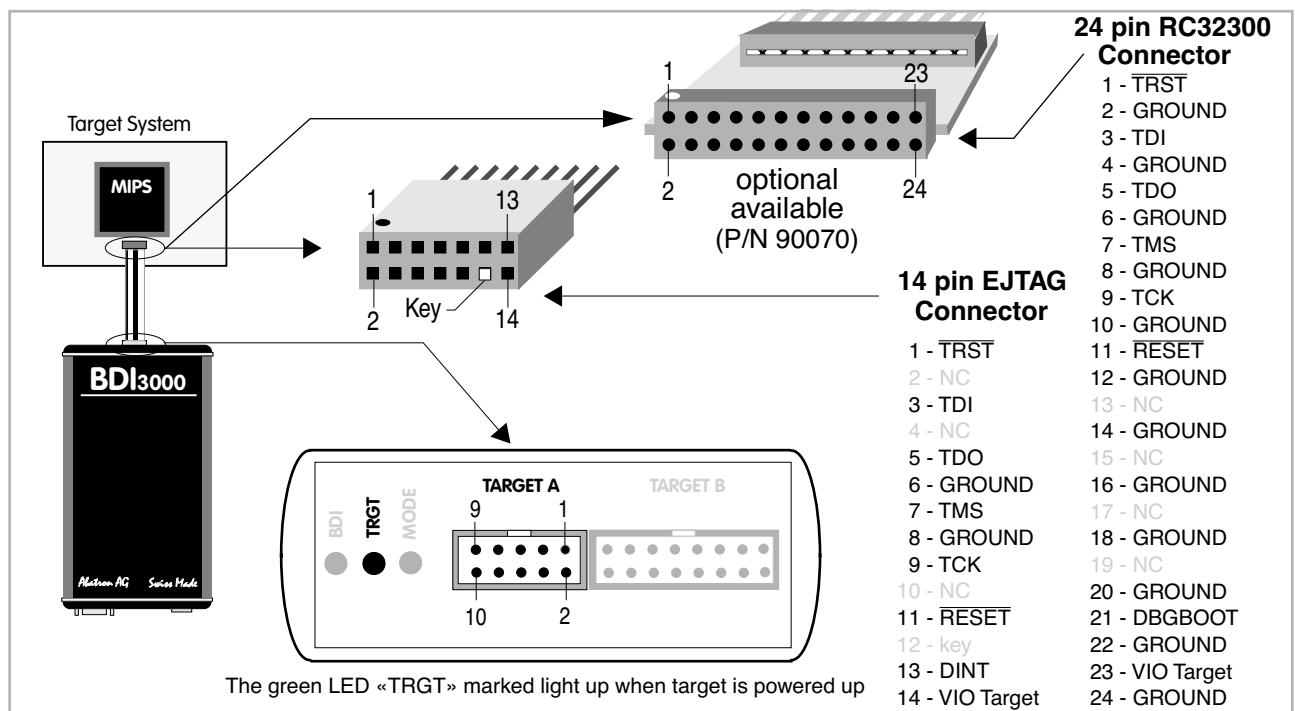

For BDI TARGET A connector signals see table on next page.

#### Warning:

Before you can use the BDI3000 with an other target processor type (e.g. MIPS <--> ARM), a new setup has to be done (see chapter 2.5). During this process the target cable must be disconnected from the target system.



To avoid data line conflicts, the BDI3000 must be disconnected from the target system while programming a new firmware for an other target CPU.

**BDI MAIN / TARGET A Connector Signals**

| Pin | Name                      | Description  |
|-----|---------------------------|--|
| 1   | DINT                      | <b>EJTAG Debug Interrupt</b><br>EJTAG 2.5: This output of the BDI3000 connects to the target DINT line.<br>RC32300: This output of the BDI3000 connects to the target DebugBoot line.  |
| 2   | $\overline{\text{TRST}}$  | <b>EJTAG Test Reset</b><br>This output of the BDI3000 resets the JTAG TAP controller on the target.  |
| 3+5 | GND                       | <b>System Ground</b>   |
| 4   | TCK                       | <b>EJTAG Test Clock</b><br>This output of the BDI3000 connects to the target TCK line.   |
| 6   | TMS                       | <b>EJTAG Test Mode Select</b><br>This output of the BDI3000 connects to the target TMS line.   |
| 7   | $\overline{\text{RESET}}$ | This open collector output of the BDI3000 is used to reset the target system.  |
| 8   | TDI                       | <b>EJTAG Test Data In</b><br>This output of the BDI3000 connects to the target TDI line.   |
| 9   | VIO Target                | <b>1.2 – 5.0V:</b><br>This is the target reference voltage. It indicates that the target has power and it is also used to create the logic-level reference for the input comparators. It also controls the output logic levels to the target. It is normally fed from Vdd I/O on the target board. |
| 10  | TDO                       | <b>EJTAG Test Data Out</b><br>This input to the BDI3000 connects to the target TDO line.   |

## 2.2 Connecting the BDI3000 to Power Supply

The BDI3000 needs to be supplied with the enclosed power supply from Abatron (5VDC).



Before use, check if the mains voltage is in accordance with the input voltage printed on power supply. Make sure that, while operating, the power supply is not covered up and not situated near a heater or in direct sun light. Dry location use only.



For error-free operation, the power supply to the BDI3000 must be between 4.75V and 5.25V DC. **The maximal tolerable supply voltage is 5.25 VDC. Any higher voltage or a wrong polarity might destroy the electronics.**

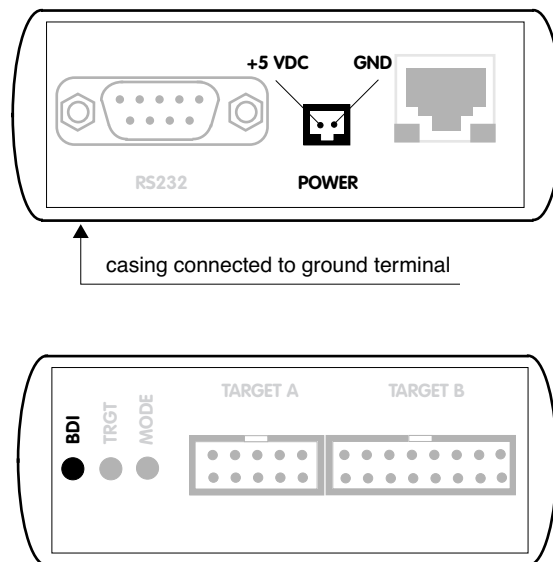

The green LED «BDI» marked light up when 5V power is connected to the BDI3000

**Please switch on the system in the following sequence:**

- 1 → external power supply
- 2 → target system

### 2.3 Status LED «MODE»

The built in LED indicates the following BDI states:

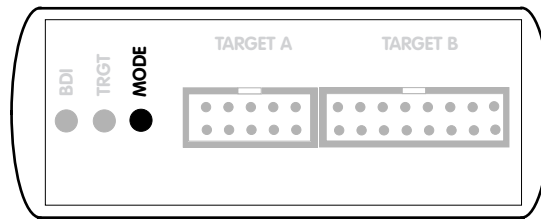

| MODE LED | BDI STATES   |
|----------|--|
| OFF      | The BDI is ready for use, the firmware is already loaded.                                      |
| ON       | The output voltage from the power supply is too low.   |
| BLINK    | The BDI «loader mode» is active (an invalid firmware is loaded or loading firmware is active). |

## 2.4 Connecting the BDI3000 to Host

### 2.4.1 Serial line communication

The host is connected to the BDI through the serial interface (COM1...COM4). The communication cable (included) between BDI and Host is a serial cable. There is the same connector pinout for the BDI and for the Host side (Refer to Figure below).

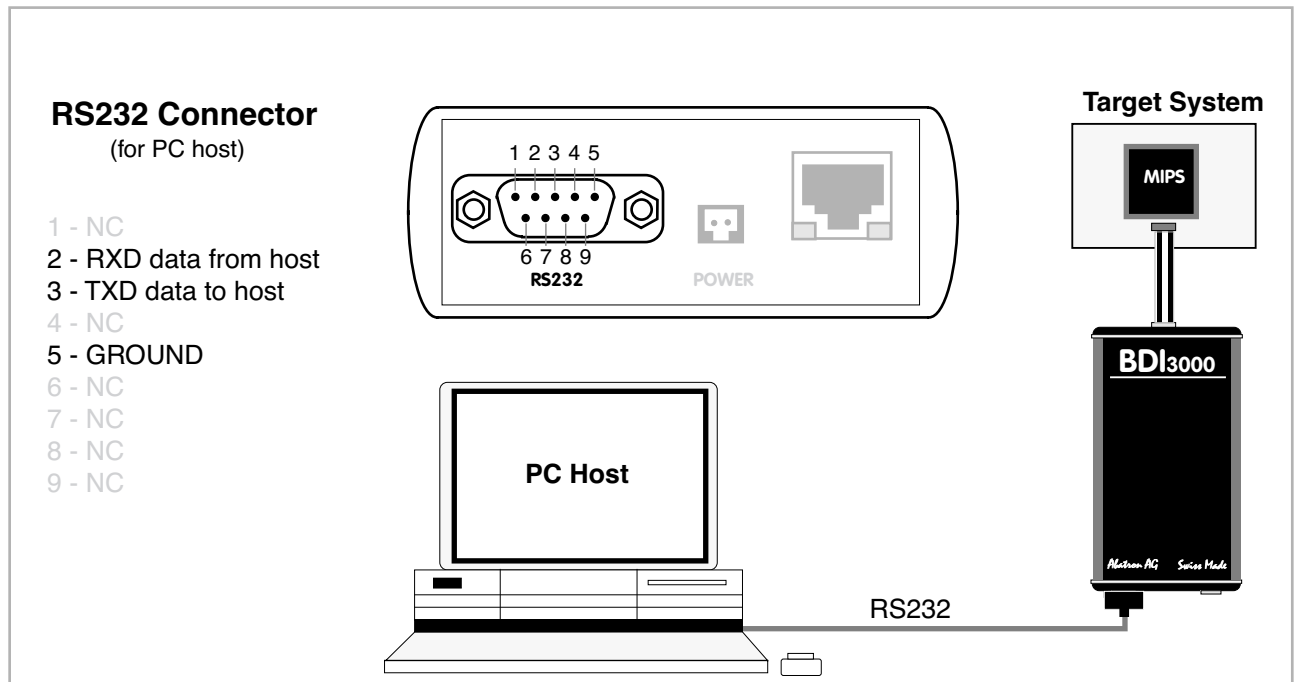

### 2.4.2 Ethernet communication

The BDI3000 has a built-in 10/100 BASE-T Ethernet interface (see figure below). Connect an UTP (Unshielded Twisted Pair) cable to the BDI3000. Contact your network administrator if you have questions about the network.

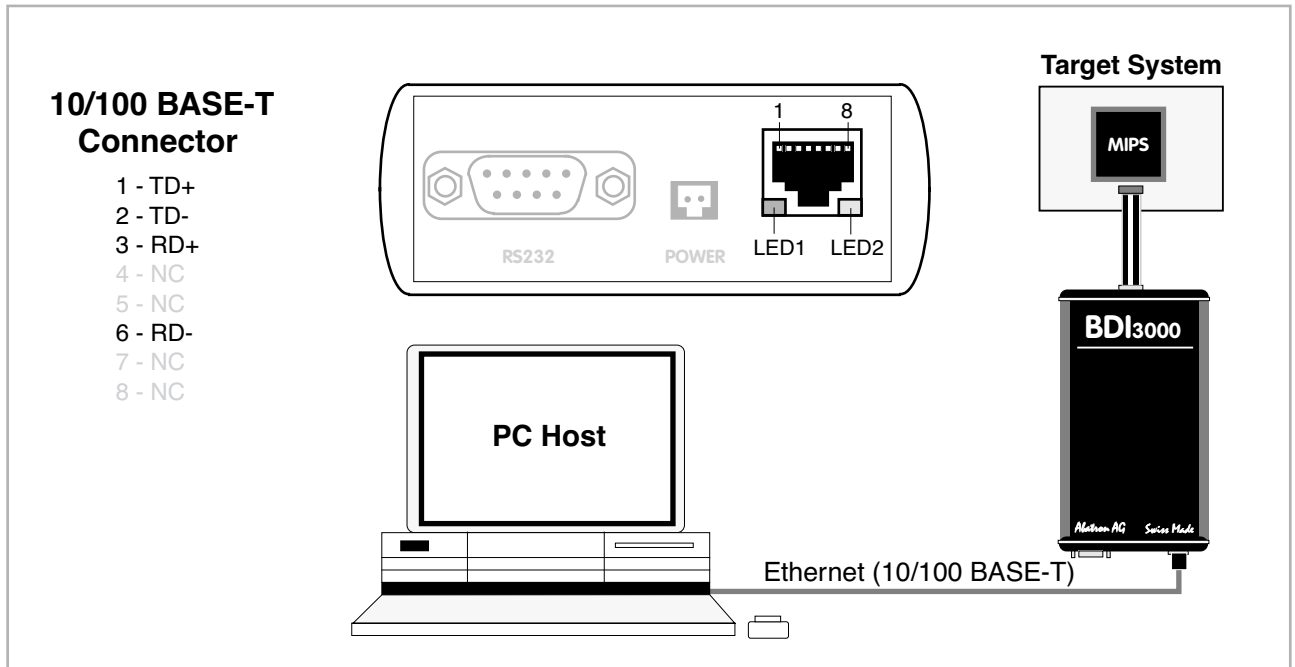

The following explains the meanings of the built-in LED lights:

| LED              | Function        | Description  |
|------------------|-----------------|--|
| LED 1<br>(green) | Link / Activity | When this LED light is ON, data link is successful between the UTP port of the BDI3000 and the hub to which it is connected.<br>The LED blinks when the BDI3000 is receiving or transmitting data. |
| LED 2<br>(amber) | Speed           | When this LED light is ON, 100Mb/s mode is selected (default).<br>When this LED light is OFF, 10Mb/s mode is selected  |

## 2.5 Installation of the bdiPro Software

On the enclosed CD you will find the bdiPro software and the firmware required for the BDI. Copy all the files to a directory on your harddisk.

The following files are on the CD:

|              |   |
|--------------|---|
| b30pgr4k.exe | bdiPro program                          |
| b30pgr4k.hlp | Helpfile for bdiPro program             |
| b30pgr4k.cnt | Help contents file                      |
| b30r4kfw.xxx | Firmware for BDI3000 for MIPS32 targets |
| bdiifc32.dll | BDI Interface DLL                       |
| xxxxxx.pro   | Predefined Program sets                 |

### Installing BDI Pro:

- Create a new directory on your harddisk, for example C:\BDIPRO.
- Copy the entire contents of the enclosed CD into this directory.

## 2.6 Configuration

Before you can use the full functionality of the bdiPro software, you must configure the system correctly. The Setup Menu enables you to perform the following configuration tasks:

- Set the correct communication parameters between the PC and the BDI. --> **Communication**
- Load or update the firmware / logic --> **Firmware**
- Configure the target system: memory type and memory organization --> **Target Memory**
- Program the initialization routines for the target system. --> **Target Initlists**

Any time you need information about specific menus and dialog boxes, you can display the integrated Help screens by pressing the F1 function key.

The Edit and Target menus will only become active when you have specified a memory type (see Target Memory in the Setup Menu).

## 2.6.1 BDI3000 Setup/Update

First make sure that the BDI is properly connected (see Chapter 2.1 to 2.4). The BDI must be connected via RS232 to the Windows host.



**To avoid data line conflicts, the BDI3000 must be disconnected from the target system while programming the firmware for an other target CPU family.**

The following dialogbox is used to check or update the BDI firmware and to set the network parameters.

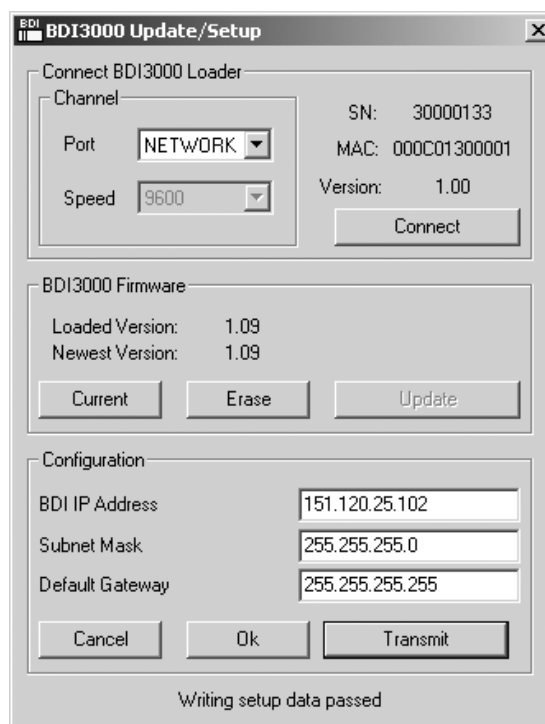

dialog box «BDI3000 Update/Setup»

The following options allow you to update the BDI3000 firmware and store the network parameters:

- |         |  |
|---------|--|
| Port    | Select the communication port where the BDI3000 is connected during this setup session.  |
| Speed   | Select the baudrate used to communicate with the BDI3000 loader during this setup session.   |
| Connect | Click on this button to establish a connection with the BDI3000 loader. Once connected, the BDI3000 remains in loader mode until it is restarted or this dialog box is closed. |
| Current | Press this button to read back the current loaded BDI3000 firmware version. The current firmware version will be displayed.  |
| Erase   | Press this button to erase the current loaded firmware.  |

---

|                 |  |
|-----------------|--|
| Update          | This button is only active if there is a newer firmware version present in the execution directory of the setup software. Press this button to write the new firmware into the BDI3000 flash memory.   |
| BDI IP Address  | Enter the IP address for the BDI3000. Use the following format:<br>xxx.xxx.xxx.xxx e.g.151.120.25.101<br>Ask your network administrator for assigning an IP address to this BDI3000. Every BDI3000 in your network needs a different IP address.                   |
| Subnet Mask     | Enter the subnet mask of the network where the BDI is connected to.<br>Use the following format: xxx.xxx.xxx.xx.e.g.255.255.255.0<br>A subnet mask of 255.255.255.255 disables the gateway feature.<br>Ask your network administrator for the correct subnet mask. |
| Default Gateway | Enter the IP address of the default gateway. Ask your network administrator for the correct gateway IP address. If the gateway feature is disabled, you may enter 255.255.255.255 or any other value.  |
| Transmit        | Click on this button to store the configuration in the BDI3000 flash memory.   |

**Default IP: 192.168.53.72**

Before the BDI is configured the first time, it has a default IP of 192.168.53.72 that allows an initial configuration via Ethernet. If your host is not able to connect to this default IP, then the initial configuration has to be done via the serial connection.

**Note:**

If there is currently a bdiGDB firmware loaded, setup via the Network channel is only possible if the BDI3000 is already in Loader mode (Mode LED blinking). To force Loader mode, enter "boot loader" at the Telnet. The setup tool tries first to establish a connection to the Loader via the IP address present in the "BDI IP Address" entry field. If there is no connection established after a time-out, it tries to connect to the default IP (192.168.53.72).

### 3 Specifications

|                                     |  |
|-------------------------------------|--|
| Operating Voltage Limiting          | 5 VDC $\pm$ 0.25 V                     |
| Power Supply Current                | typ. 500 mA<br>max. 1000 mA            |
| RS232 Interface: Baud Rates         | 9'600, 19'200, 38'400, 57'600, 115'200 |
| Data Bits                           | 8                                      |
| Parity Bits                         | none                                   |
| Stop Bits                           | 1                                      |
| Network Interface                   | 10/100 BASE-T                          |
| BDM/JTAG clock                      | up to 32 MHz                           |
| Supported target voltage            | 1.2 – 5.0 V                            |
| Operating Temperature               | + 5 °C ... +60 °C                      |
| Storage Temperature                 | -20 °C ... +65 °C                      |
| Relative Humidity (noncondensing)   | <90 %rF                                |
| Size                                | 160 x 85 x 35 mm                       |
| Weight (without cables)             | 280 g                                  |
| Host Cable length (RS232)           | 2.5 m                                  |
| Electromagnetic Compatibility       | CE compliant                           |
| Restriction of Hazardous Substances | RoHS 2002/95/EC compliant              |

Specifications subject to change without notice

## 4 Environmental notice



Disposal of the equipment must be carried out at a designated disposal site.

## 5 Declaration of Conformity (CE)

  
**DECLARATION OF CONFORMITY**

This declaration is valid for following product:

**Type of device: BDM/JTAG Interface**  
**Product name: BDI3000**

The signing authorities state, that the above mentioned equipment meets the requirements for emission and immunity according to

**EMC Directive 89/336/EEC**

The evaluation procedure of conformity was assured according to the following standards:

**IEC 61000-6-2: 1999, mod. EN61000-6-2: 2001**  
**IEC 61000-6-3: 1996, mod. EN61000-6-2: 2001**

This declaration of conformity is based on the test report no. E1087-05-7a of Quinel, Zug, Swiss Testing Service, accreditation no. STS 037

Manufacturer:

**ABATRON AG**  
**Lettenstrasse 9**  
**CH-6343 Rotkreuz**

Authority:

  
Max Vock  
Marketing Director

  
Ruedi Dummermuth  
Technical Director

Rotkreuz, 7/18/2007

## 6 Warranty

ABATRON Switzerland warrants the physical CD, cable and BDI3000 to be free of defects in materials and workmanship for a period of 3 years following the date of purchase when used under normal conditions.

In the event of notification within the warranty period of defects in material or workmanship, ABATRON will replace defective CD, cable or BDI3000. The remedy for breach of this warranty shall be limited to replacement and shall not encompass any other damages, including but not limited loss of profit, special, incidental, consequential, or other similar claims.

ABATRON Switzerland specifically disclaims all other warranties - expressed or implied, including but not limited to implied warranties of merchantability and fitness for particular purposes - with respect to defects in the CD, cable and BDI3000, and the program license granted herein, including without limitation the operation of the program with respect to any particular application, use, or purposes. In no event shall ABATRON be liable for any loss of profit or any other commercial damage, including but not limited to special, incidental, consequential, or other damages.

Failure in handling which leads to defects are not covered under this warranty. The warranty is void under any self-made repair operation.

## Appendices

### A Troubleshooting

#### Problem

The firmware can not be loaded.

#### Possible reasons

- The BDI is not correctly connected with the Host (see chapter 2).
- A wrong communication port is selected (Com 1...Com 4).
- The BDI is not powered up

#### Problem

No working with the target system (loading firmware is okay).

#### Possible reasons

- Wrong pin assignment (BDM/JTAG connector) of the target system (see chapter 2).
- Target system initialization is not correctly → enter an appropriate target initialization list.
- An incorrect IP address was entered (BDI3000 configuration)
- BDM/JTAG signals from the target system are not correctly (short-circuit, break, ...).
- The target system is damaged.

#### Problem

Network processes do not function (loading the firmware was successful)

#### Possible reasons

- The BDI3000 is not connected or not correctly connected to the network (LAN cable or media converter)
- An incorrect IP address was entered (BDI3000 configuration)

## **B Maintenance**

The BDI needs no special maintenance. Clean the housing with a mild detergent only. Solvents such as gasoline may damage it.

## **C Trademarks**

All trademarks are property of their respective holders.